

FULFILLING THE PROMISE OF THE SMART GRID

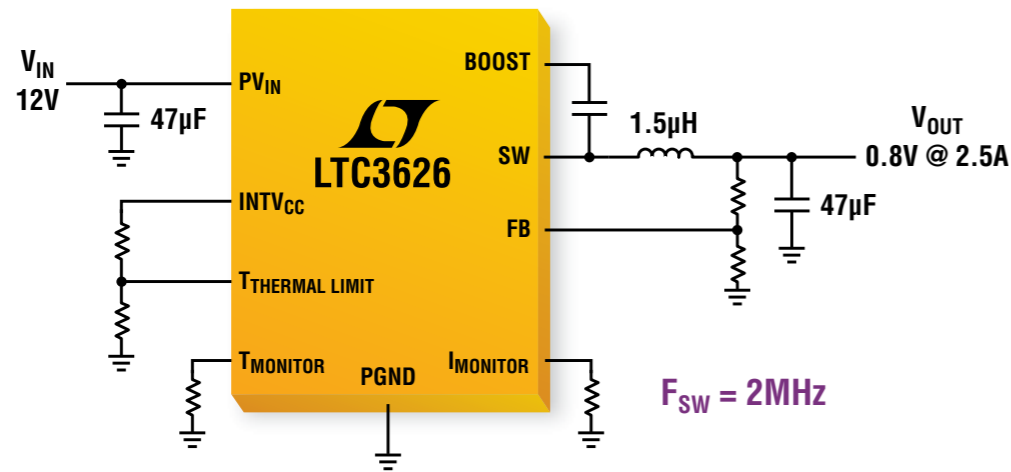

20V, 2.5A SWITCHER+



Programmable Input & Output Current Limits and Monitoring with Die Temp Sensing

The LTC[®]3626 SWITCHER+™ is the first member of a new switcher family featuring programmable input and output current limits, as well as on-chip die temperature monitoring with programmable thermal shutdown. These features provide enhanced system level protection, control and real time status readings. Plus, its unique controlled on-time architecture is ideal for high step-down ratios where high switching frequencies and fast transient response are essential. The LTC3626 combines up to 3MHz switching with a small, compact solution footprint.

Features

- 2.6V to 20V Input Voltage
- Wide Output Voltage Range: 0.6V to 97%V_{IN}
- 95% Efficient
- Up to 2.5A Output Current
 - Average Input and Output Current Monitoring (IMON_{IN}, IMON_{OUT})
 - Programmable Average Input/Output Current Limit
 - Die Temp Monitor and Programmable Limit (TSET)

Output Current Monitor Error

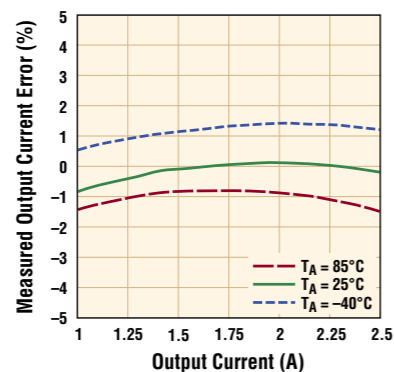

Info & Free Samples

www.linear.com/product/LTC3626
+49-89-962455-0



cds.linear.com/docs/Design%20Note/dn511.pdf

LT, LT, LTC, LTM, Linear Technology and the Linear logo are registered trademarks and Switcher+ is a trademark of Linear Technology Corporation. All other trademarks are the property of their respective owners.

Europe Sales offices: France 33-1-41079555 Italy 39-02-38093656 Germany 49-89-9624550 Sweden 46-8-623-1600 UK 44-1628-477066 Finland 358-9-88733699 Distributors: Belgium ACAL 32-0-2-7205983 Finland Tech Data 358-9-88733382 France Arrow Electronique 33-1-49-784978, Tekelec Airtronic 33-1-56302425 Germany Insight 49-89-611080,



Setron 49-531-80980 Ireland MEMEC 353-61-411842 Israel Arnet Components 972-9-778-0351 Italy Silverstar 39-02-66125-1 Netherlands ACAL 31-0-402502602 Spain Arrow 34-91-304-3040 Turkey Arrow Elektronik 90-216-4645090 UK Arrow Electronics 44-1234-791719, Insight Memec 44-1296-330061



Empowering Global Innovation

WWW.POWERSYSTEMSDESIGN.COM

Visit us online for exclusive content; Industry News, Products, Reviews, and full PSD archives and back issues

2 VIEWpoint

It's up to us to create the future
By Alix Paultre, Editorial Director, Power Systems Design

4 POWERline

PMIC from ams monitors & balances lithium cells

6 POWERplayer

Rear Admiral Pease helps launch Energy Focus Advisory Board
By Julia Dolsen, Energy Focus

8 MARKETwatch

Solar Power Inverter Demand Grows as Revenues Decline
By Cormac Gilligan, HIS

9 DESIGNtips

Point-Of-Load Converter Design
By Dr. Ray Ridley, Ridley Engineering

COVER STORY

14 Energy Measurement Fulfills Promises of the Smart Grid

By Gordon Lee, Maxim Integrated

TECHNICAL FEATURES

18 Power Semiconductors

Normally-Off and Current Collapse Free by Unique GIT Technology Realize Commercialization of GaN Transistor
By Howard Sin, Panasonic

22 Power Semiconductors

High-performance resistors in custom power supplies
By Phil Ebbert, Riedon

SPECIAL REPORT: SOLAR AND WIND ELECTRONICS

28 Predicting the Grid

By Edward H. Kennedy, Tollgrade Communications

31 SiC poised to revolutionize solar power inverters

By Jeffery Casady & Paul Kierstead, Cree

34 Italian project delivers zero emission power from biomass

By Ing. Alessio Vaccari, CPL Concordia

38 Nanopower energy harvesting dramatically extends battery life

By Jeff Gruetter, Linear Technology

43 Supercapacitors enable energy harvesting in space-constrained apps

By Pierre Mars, CAP-XX

FULFILLING THE PROMISE OF THE SMART GRID



COVER STORY

Energy Measurement Fulfills Promises of the Smart Grid (pg 14)

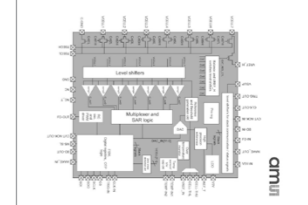

Highlighted Products News, Industry News and more web-only content, to:

www.powersystemsdesign.com

48 GREENpage

Nuclear power's problems
By Alix Paultre, Editorial Director, Power Systems Design

48 Dilbert

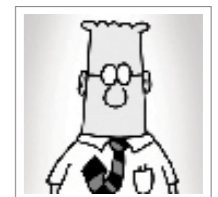



AGS Media Group
146 Charles Street
Annapolis, MD 21401 USA
Tel: +410.295.0177
Fax: +510.217.3608
www.powersystemsdesign.com

Editorial Director
Alix Paultre, Editorial Director,
Power Systems Design
alixp@powersystemsdesign.com

Contributing Editors
Liu Hong, Editor-in-Chief,
Power Systems Design China
powersdc@126.com

Ryan Sanderson, IMS Research
ryan.sanderson@imsresearch.com

Dr. Ray Ridley, Ridley Engineering
RRidley@ridleyengineering.com

Publishing Director
Jim Graham
jim.graham@powersystemsdesign.com

Publisher
Julia Stocks
julia.stocks@powersystemsdesign.com

Production Manager
Chris Corneal
chris.corneal@powersystemsdesign.com

Online Content Manager
Christie Penque
christie.penque@powersystemsdesign.com

Magazine Design
Louis C. Geiger
louis@agencyofrecord.com

Registration of copyright: January 2004
ISSN number: 1613-6365

AGS Media Group and Power Systems Design Europe magazine assume and hereby disclaim any liability to any person for any loss or damage by errors or omissions in the material contained herein regardless of whether such errors result from negligence, accident or any other cause whatsoever. Send address changes to: circulation@powersystemsdesign.com

Free Magazine Subscriptions, go to:
www.powersystemsdesign.com

Volume 10, Issue 9



It's up to us to
create the future

It is now obvious to even the most casual observer that we are in a time of disruptive change, precipitated by technical advances we are still struggling to come to grips with at every level, from the design bench to the legislative chamber. While society continues to absorb and integrate the challenges and opportunities provided by the Internet, among other things, the design and manufacturing community continues to create technologies and products that continue to expand the scope of available functionality and the resulting expanded impact on us.

The engineering community has been confronted with technical developments creating real societal issues since fire was mastered. The current integrating and leveraging forces of powerful personal devices, cloud-based system architectures, and the concept of power and data being necessities in a modern economy continue to underscore this fact.

Who decides who gets priority in a negotiated-power economy based on a cloud-reinforced smart grid? Will power exchanges buy and sell power with the current speed and aggressiveness of the stock market's high-speed trading software? Will your washer negotiate with the grid as to when it can turn on? In a brownout condition, who gets to decide on demand priority? Hospitals are no-brainers, but what about fire stations? Supermarkets? Your competitor's facility?

In integrated command structures, who decides how the variety of subsystems involved develops a hierarchy? Can your smartphone override your house's pre-programmed thermostat? What about when your utility is trying to turn it down? In a smart home, does Dad's personal service app outrank Mom's when they're in the same room? What communications protocol should be used across the infrastructure to ensure all involved devices can communicate properly? Should there be physical plug standards to enable devices to be plugged into kiosks and such?

We as an industry must decide, for who else understands the emerging smart grid as well as the engineers involved in its development? The challenge lies in the fact that the future smart-grid infrastructure will span multiple disciplines and industries, and many of these industries don't even have a common frame of reference for devices, technologies, or even measurements.

What we need to do is expand the current inter-agency, inter-industry, and inter-discipline outreach currently going on by organizations like the PSMA and IEEE, agree on some cross-platform common standards, techniques, measurements, and methodologies (we can move on to legislative stuff once we have a common frame of reference for everyone) so that we can create the best future we are capable of.

Best Regards,

Alix Paultre

Editorial Director, Power Systems Design
alixp@powersystemsdesign.com

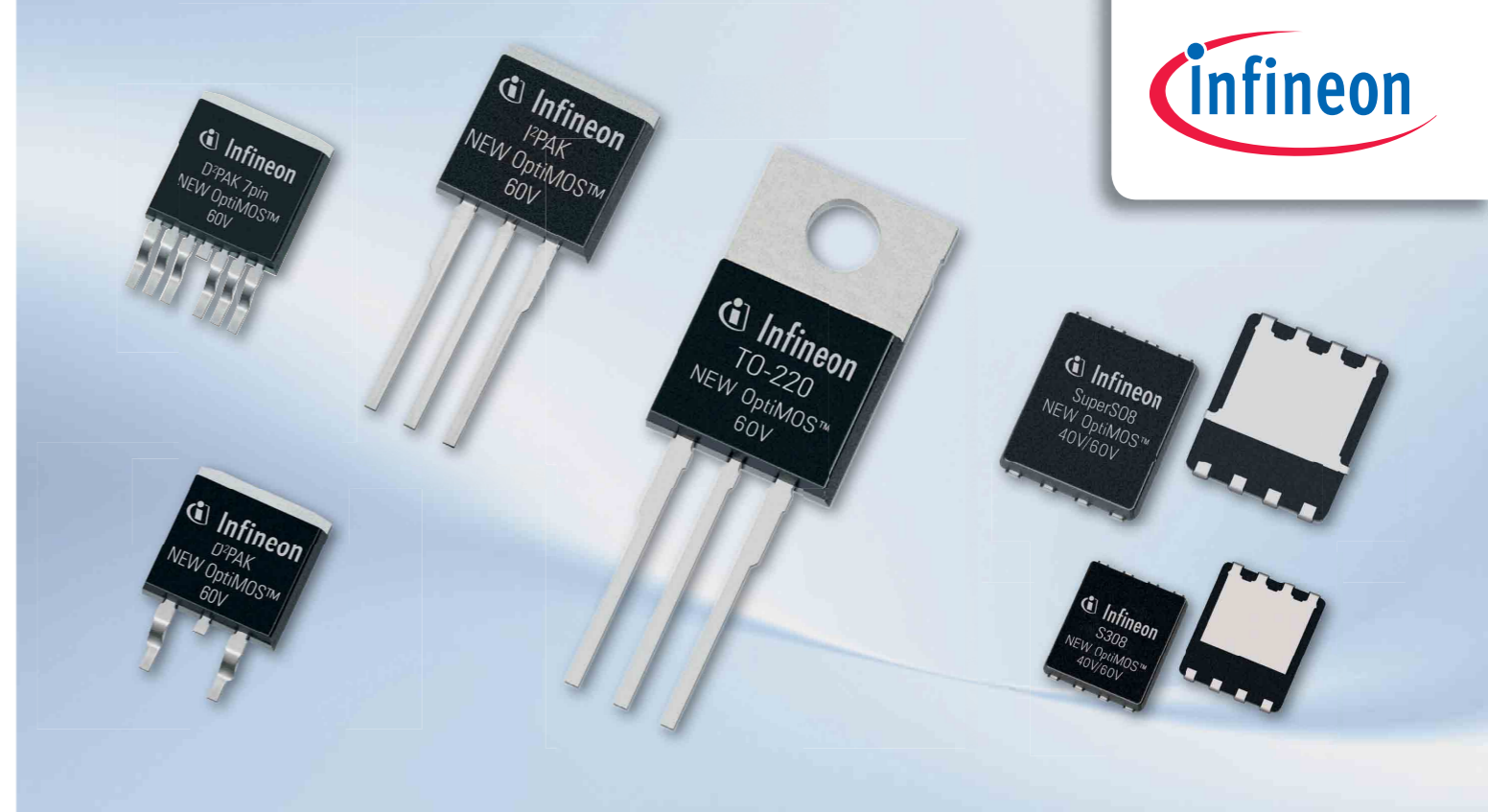

New OptiMOS™ 40V and 60V Enables 96% Efficiency Level in Server Power Supply



Infineon's new OptiMOS™ 40V and 60V family is optimized for synchronous rectification in Switched Mode Power Supplies (SMPS) such as in servers and desktop PCs. These devices set the highest standards in power density and efficiency and at the same time reduce system costs.

The new OptiMOS™ 40V/60V families are also a perfect choice for a broad range of industrial applications like motor control, solar micro inverter and DC/DC converter like in telecom.

Key features and benefits of new OptiMOS™ 40V/60V

- Industry's first 1mΩ 40V and 1.4mΩ 60V products in SuperSO8
- 35% lower $R_{DS(on)}$ and 45% lower FOM than alternative devices
- Highest system efficiency and power density
- Monolithically integrated Schottky like diode for highest efficiency



For further information please visit our website:
www.infineon.com/newoptimos



PMIC from ams monitors & balances lithium cells

Ams, a leading provider of high performance analog ICs and sensors, introduced a vastly simplified and more robust method of implementing cell monitoring and balancing in lithium battery systems. The AS8506 can perform distributed cell monitoring and balancing operations for stacked cell modules, including Safe Operating Area (SOA) checks and passive or active cell balancing. It is ideal for all lithium-based cell chemistries, such as those found in hybrid and fully electric vehicles, as well as for EDLCs (also known as supercaps or ultracaps).

In conventional systems, a complicated algorithm running remotely on a high-end microcontroller decides which cells have to be balanced. The new architecture supported by the AS8506 can control balancing locally at the cells, enabling designers to implement a more streamlined cell management system that eliminates the powerful host controller, complex software and vulnerable serial communication links normally used today.

The AS8506 can implement both passive and active cell balancing autonomously, or it can support a microcontroller-based system via its Serial Peripheral Interface.

An advanced analog circuit in the AS8506 compares up to seven cell voltages against an internal or external reference with an accuracy of 1mV, to support cell-balancing and cell-monitoring functions. Cell voltage measurements can also be digitized with an accuracy of 4mV and reported to a host controller.

Active and passive cell balancing use a similar circuit design, but active balancing requires an additional flyback transformer. The control circuit is integrated in the AS8506.

The device also features internally or external adjustable upper and lower cell voltage limits. Temperature measurement is carried out through two external NTC sensors.

The fully autonomous cell management architecture enabled by the AS8506 is in stark contrast to the typical system implementations found today using existing cell monitoring ICs. These are typically limited to the sequential capturing of cell voltage measurements that must be processed by a host controller.

These prior architectures have several drawbacks for designers of battery management systems:

- The system must stream large

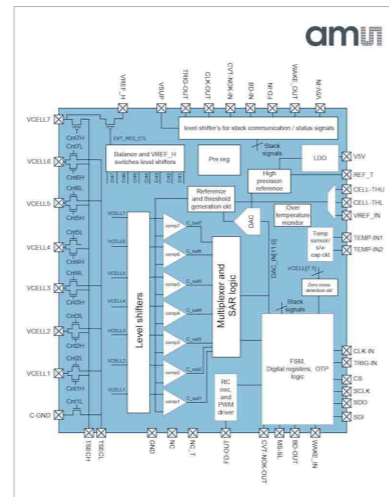

amounts of data over a serial link – a communications channel that is vulnerable to interference in noisy environments.

- A powerful host controller running complex software is required to turn individual cell voltage measurements into useful functions such as cell balancing decisions. Writing this software is a difficult and time-consuming task. The software requires exhaustive testing in order to qualify for use in automotive ISO26262-compliant systems.
- Sequential cell measurements require complex compensation algorithms in order to produce valid voltage and current readings across a stack of cells. By contrast, the simultaneous measurements captured by the AS8506 require no compensation.

www.ams.com

Purchase Mitsubishi & Powerex Inventory in Stock Online by Credit Card

- Quality Products
- Impeccable Service
- Convenient Purchasing Options



www.pwrx.com/support/HowToPurchase.aspx



www.pwrx.com
001 724-925-7272





Rear Admiral Pease helps launch Energy Focus Advisory Board

By: Julia Dolsen, Energy Focus

Energy Focus announced the creation of an Energy Focus Advisory Board to be comprised of leading experts in government and commercial markets. The board will be to help penetrate significant market segments by bringing key industry insights and connections to critical decision-making networks to Energy Focus as they grow their LED retrofit businesses.

"After serving 30 years in the U.S. Navy and spending 15 years at General Dynamics, Rear Admiral Pease is an ideal choice for our inaugural Advisory Board member. Rear Admiral Pease worked not only as the Navy's Chief of Information, but also more recently as General Dynamics' vice president of government relations. His vast wealth of experience and understanding of United States Navy and government contracting procedures will be invaluable in our initiative to expedite LED adoption throughout the military fleet," according to James Tu, Energy Focus Executive Chairman.

Eric Hilliard, Energy Focus President and Chief Operating Officer

adds, "We very much look forward to the Rear Admiral's support as we transform the Navy's lighting from its legacy incandescent and fluorescent technology to an all LED solution. Energy Focus' military LED product line, which includes our IntelliTube(R) - technology, will bring much reduced life cycle costs as well as significant ongoing energy savings due to its superior efficiency."

"I am pleased to join Energy Focus as an Advisory Board member to help the Company continue to bring energy efficient lighting products to the fleet, which will be critical in meeting the fuel savings targeted by the Secretary of the Navy," said Rear Admiral Pease, USN retired. "Energy Focus' LED lighting technology is an important element in fostering good economics for the Navy, and it's also equally important as a strategic factor in elevating fleet readiness upon which we all rely."

About Kendall

Pease Kendall Pease became General Dynamics vice president -- Government Relations and Communications in May 2006.

He previously had served as vice president -- Communications, since May 1998, when he joined General Dynamics. Pease retired from General Dynamics in January of this year after 15 years with the Company and is now heading a Government Relations and Public Relations consulting firm.

Prior to joining General Dynamics, Pease served 30 years in the U.S. Navy as a public affairs officer and was the Navy's Chief of Information from July 1992 to April 1998. He retired from active duty in May 1998 as a rear admiral.

Pease enlisted in the U.S. Navy in 1963. He received a bachelor's degree from the U.S. Naval Academy in 1968 and a master's degree in mass communications from American University in 1975. Society of America for excellence in public relations. He is a member of the board of the Armed Services YMCA, Metro-USO, Trustee, United States Naval Academy Foundation, Trustee, US Naval Institute and is on the board of Heroes & Families Foundation.

www.energyfocusinc.com

Does your digital power-supply design controller require high performance flexible on-chip peripherals?...

Control complex Digital Power applications and save power



Microchip's new dsPIC33F 'GS' Series DSCs provide on-chip peripherals including high-speed Pulse-Width-Modulators (PWMs), ADCs and analogue comparators, specifically designed for high performance, digital power supplies.

The powerful dsPIC33F 'GS' series is specifically aimed at power control applications and can be configured for a variety of topologies, giving power-supply designers the complete freedom to optimise for specific product applications. Multiple independent power control channels enable an unprecedented number of completely independent digital control loops. The dsPIC33F 'GS' series offers the optimal digital power solution supported by royalty free reference designs and advanced power design tools.

Typical applications for the new 'GS' series DSC include: Lighting (HID, LED, fluorescent), uninterruptable power supplies, intelligent battery chargers, AC-DC and DC-DC power converters, solar and pure sine-wave inverters, induction cooking, and power factor correction.

- Digital control loops with up to 18 high-speed, 1 ns resolution PWMs
- Up to 24 channels 10-bit on-chip ADCs
- 2 to 4 Million Samples Per Second (MSPS) ADC for low latency and high-resolution control
- Pin range: 18 to 64
- Up to 64KB Flash memory

GET STARTED IN 3 EASY STEPS:

1. Purchase a 'GS' Series Plug-In Module
2. Download Digital Power Reference Design
3. Order samples and start designing!

www.microchip.com/power

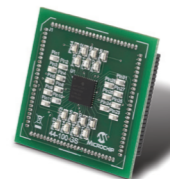

dsPIC33F 'GS' Series Plug-In Module (MA330024)

For more information, go to: www.microchip.com/power



Microcontrollers • Digital Signal Controllers • Analog • Memory • Wireless



Solar Power Inverter Demand Grows as Revenues Decline

By: Cormac Gilligan, HIS

Despite turbulent conditions across the solar power industry, with government policies on renewables constantly changing, solar inverter shipments will increase once again in 2013. However, a highly competitive market environment has led to fierce price pressure; industry revenues will decline as a result.

In 2013, global solar inverter shipments are forecast to increase by 7% to 34.6 GW, largely due to demand in the US, Japanese and Chinese markets. In contrast, lower government subsidies in the large mature markets of Germany and Italy, which had previously been the biggest in the world, will result in declining demand there.

The latest data from IHS show that global shipments in the first half of 2013 reached 15.5 GW; they are projected to increase by 23 percent to 19.1 GW in the second half, as many inverters will be shipped to utility-scale projects. This is according to the IHS report entitled "The World

Market for PV Inverters - 2013 Edition".

Intense challenges for suppliers
However, despite the increased inverter shipments, serious challenges face suppliers. Global inverter prices are forecast to decrease by 14% in 2013 as the mature markets of Germany and Italy contract. In some of the Asian markets such as India, Thailand and China, central inverter prices have reached as low as \$0.06 per watt; this has meant that some suppliers have not been able to enter these markets as their prices would not be competitive enough and as they do not have the necessary local manufacturing presence to compete.

As some of the established large markets in Europe have become smaller, inverter suppliers now need to establish themselves in new PV markets. Some of these markets, such as that in South Africa, have local content requirements; suppliers have thus to make significant investment to compete in them. Suppliers also need to get their

products certified in the new markets and to set up after-sales service so that customers can have their inverters repaired in the event of a failure.

Inverter pricing pressure to hit revenues

Inverter revenues are forecast to decrease by 7 percent in 2013 to \$6.5 billion as inverter prices fall for all power ratings. Pricing pressure will be most intense for three-phase 10-35 kW inverters and large central inverters greater than 250 kW, as inverter suppliers are offering very competitive prices to win large commercial and utility-scale projects.

However, there will be some respite for inverter suppliers in 2014. Revenues are forecast to rebound to \$7.1 billion, as inverter shipments

www.ihs.com



Point-Of-Load Converter Design

By: Dr. Ray Ridley, President, Ridley Engineering

There has always been a debate about how essential it is to measure the loop of a switching power supply. Some power designers have always resisted this part of development and design validation, claiming they are able to tune a loop properly through step-load testing [1]. While this may have worked with low performance power supplies, it is increasingly difficult with modern high-performance systems.

Seven things have happened in recent years that have brought the loop testing issue back to the forefront. These issues combine to create a much higher risk of power supply instability:

1. Power converter switching frequencies have been raised significantly to 2 MHz or more.
2. Multiple point-of-load power supplies are incorporated on a single electronics assembly
3. Input and output capacitors are comprised of just multilayer ceramics with negligible ESR
4. Each converter minimizes the output capacitance to reduce board area

5. Loop gains have become very aggressive in order to meet step-load requirements
6. Some or all of the power supply compensation is internal to the integrated power supply
7. Voltage-mode control is being used in place of current-mode control

Most application notes for these supplies tend to imply that their design is straightforward, and no more complicated than putting a linear regulator on the board. This can get many system designers into trouble. Now let's look at each of these seven risk issues.

1. High Switching Frequencies

Switching frequencies have risen substantially in the last 10 years as more and more regulators are forced onto boards in close proximity to the processors that they are supplying. 100 kHz switching is no longer sufficient since it results in large inductors and capacitors that simply won't fit in the space available. As switching frequencies climb, much greater demands are placed upon feedback amplifiers and layout. Both the power

stage and feedback networks can exhibit small-signal and large-signal behaviors that are not accurately predicted by the modeling.

2. Multiple Converters on Assembly

With so many regulators on a board, the probability of a marginal design increases. Furthermore, proper testing of each regulator can seem daunting and overly time-consuming. If the makers of the parts do not suggest loop gain testing, it is unlikely that non-power engineers will even consider doing any. And when the power supplies are designed into the boards, there are usually no provisions made for loop. This can either increase the difficulty of test, or sometimes render it impossible when traces are placed in inner layers that are not accessible.

3. Multilayer Ceramic Capacitors

Multilayer ceramic capacitors have extremely low esr values, and very little capacitance is needed to meet output ripple requirements. Hence the power supply makers can minimize the design area, leaving it up to the

electronics assembly designer to add more capacitance as needed. On the input side of the converter, if additional filtering is used for noise attenuation, a series inductor can resonate with the low-esr capacitors to form a peak in filter output impedance. This can lead to classic input filter oscillation issues [2].

4. Minimum Output Capacitance

As the output capacitance reduces, the converter is far more sensitive to capacitive loading. In the earlier days of power supply design, the capacitance in the converter would dominate any loading capacitance, making the loop response relatively impervious to any additions. This is no longer true, and local bypass capacitance at the load can be significantly larger than the power supply capacitance for which the loop has been optimized.

5. Aggressive Loop Gains

Most power supplies in the past would have loop gains, which were very conservative. It is not unusual to find a crossover frequency of just 1 kHz or less for a 100 kHz converter. This is rapidly changing for point-of-load converters. It is not uncommon now to find loop gains well in excess of 1/10 the switching frequency. As this crossover frequency increases, the power stage models become less reliable, and the measured

response does not follow theory so closely. Also, with high crossover frequencies, the gain-bandwidth of the error amplifier becomes a limiting factor. It is essential to verify these more aggressive loops if long-term instability is to be avoided.

6. Internal Compensation

Many of the new low-power switching regulators remove the burden of compensation from the user, and they include the compensation components inside the IC. This can either be just the feedback compensation components R2, C1 and C3 shown in Figure 1, or it can include the input compensation components R1, Rb, C2 and R3 as well.

The problem with this integrated approach is that the compensation components are optimized for an assumed value of L and C in the power stage. If these values change, as is almost always the case, there is no opportunity for the user to properly compensate the power stage to achieve the best loop design.

7. Voltage-Mode Control

The great benefits of current-mode control are adaptivity to the inductor value, elimination of the LC filter resonance, and naturally optimal control in either CCM or DCM regions of operation. The main downside of current-mode has always been difficulty of implementation due to worsened signal-to-

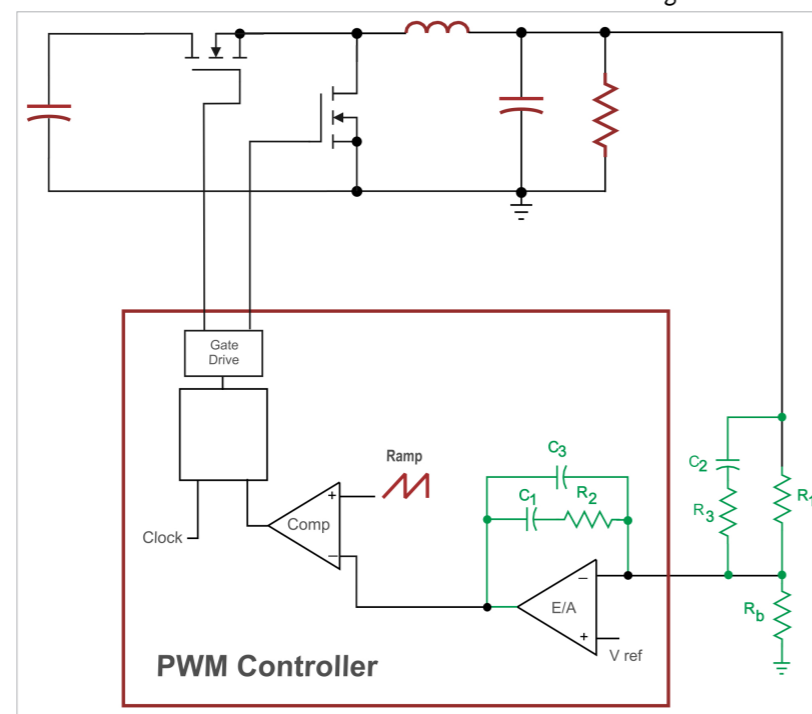

Figure 1: 400 kHz Buck Converter with Synchronous Rectifier and MLC Output Capacitor. Output voltage is 1.2 V at 20 A. Input Voltage is 12 V.

noise ratios in the modulator. This last problem is exacerbated as frequencies climb; so many integrated power supply makers have reverted back to voltage-mode control. This brings back in all of the lack of adaptivity of the loop design, and the loop gain and phase margin are much more susceptible to component variation.

In the rest of this article, we will look at how the output capacitor size interacts with loop bandwidth and the output step-load response

Effect of Capacitance on Step-Load Response

Figure 1 shows the schematic of a buck converter with a

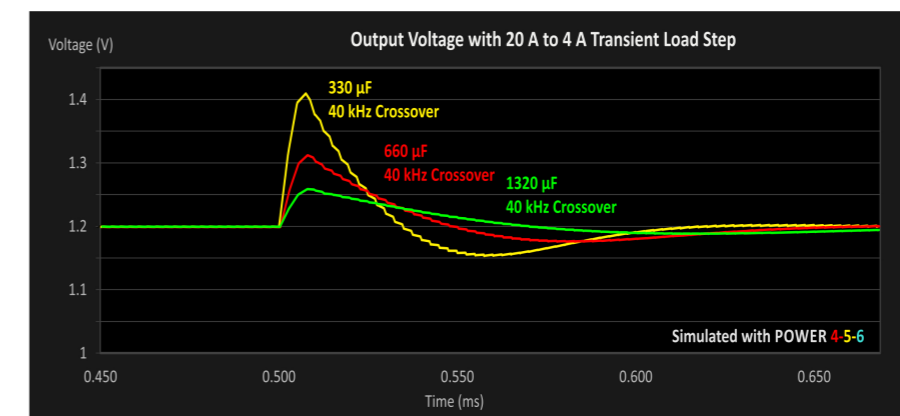

Figure 2: Output Voltage Response for Load Step From 20 A to 4 A with Different Capacitor Values

synchronous rectifier and MLC output capacitor. At a 400 kHz switching frequency, the impedance of the output capacitor is very small and

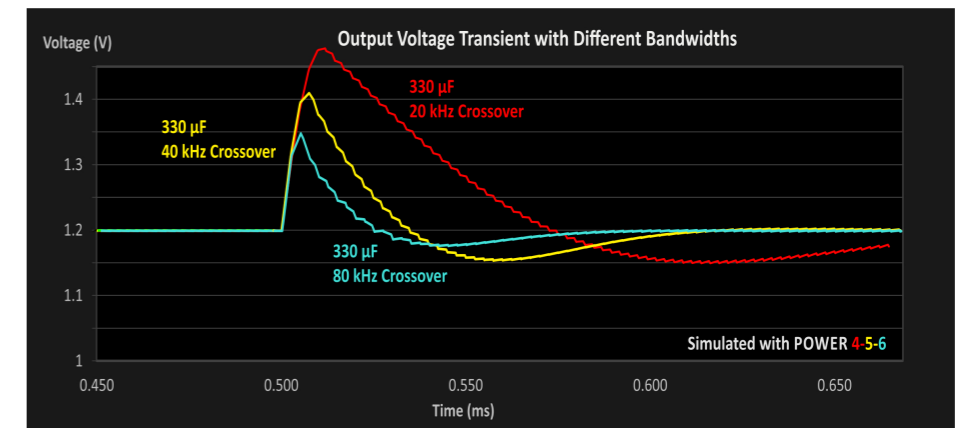

Figure 3: Output Voltage Response for Load Step From 100% to 20% with Different Crossover Frequencies

easily able to attenuate the ripple current seen from the inductor. With MLC capacitors, the value of capacitance is chosen according to the step load requirements of the system rather than the ripple requirements. During the loop response time, the output capacitor has to absorb the energy stored in the output inductor when the load is turned

off. Figure 2 shows the overshoot on the output voltage when the load is decreased from 20 A to 4 A. The peak overshoot is 200 mV with a capacitance of 330 µF and a loop crossover frequency of 40 kHz. The overshoot can obviously be reduced if the output capacitance is increased. However, the benefits of the larger output capacitor are only fully realized if the loop gain crossover frequency can be maintained at 40 kHz. This requires different compensation each time the capacitor is changed.

Effect of Loop Gain Crossover on Step-Load Response

Figure 3 shows the step-load response of the same converter with a 330-µF capacitor and different values of crossover frequency. Notice that there is NOT a linear relationship between the crossover frequency and the overshoot. As the crossover becomes more

off, and it must hold the output voltage within the regulation band when the full load is reapplied.

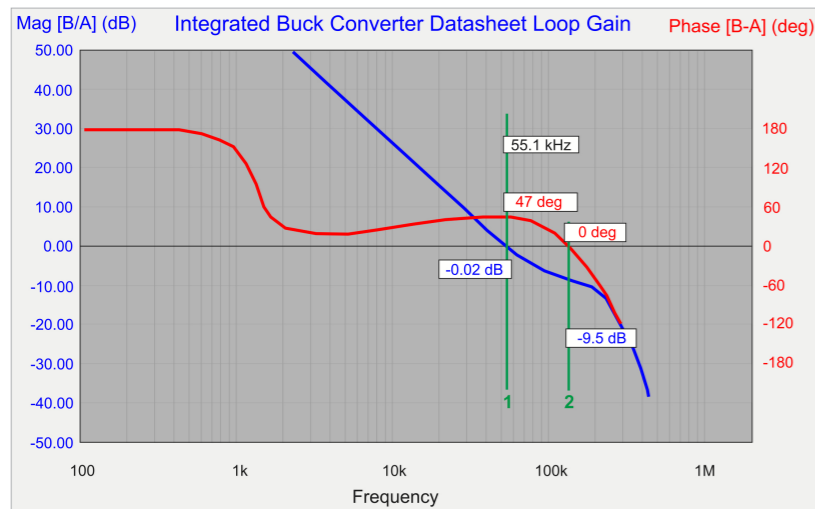

Figure 4: Semiconductor Manufacturer's Loop Gain Example from Application Note

aggressive, it is not possible to maintain the same phase margin and the output impedance exhibits a peaking in its value. This leads to an increase in the step-load response.

This demonstrates that there is a practical limit for crossover frequency above which there is little value in increasing it further. This limit tends to be about 1/10 to 1/5 the switching frequency.

Datasheets for Loop Gains

The previous two figures have shown the incentive for reducing output capacitance with loop gain. While this effect is well-known, and most of the semiconductor manufacturers use the AP300 Frequency Response Analyzer [3] for in-house characterization and testing of loops [4], it is common for power chip datasheets to downplay the need for actual loop testing in the circuit

frequency and phase margin will change significantly if the output capacitor is changed or the output inductor value is changed. It is also just one data point, and will vary with time, individual component choices, and temperature.

Injecting into the Loop

As these power supplies become smaller and smaller, it becomes increasingly rare to find a design where loop gain measurement is facilitated by the inclusion of test components and test

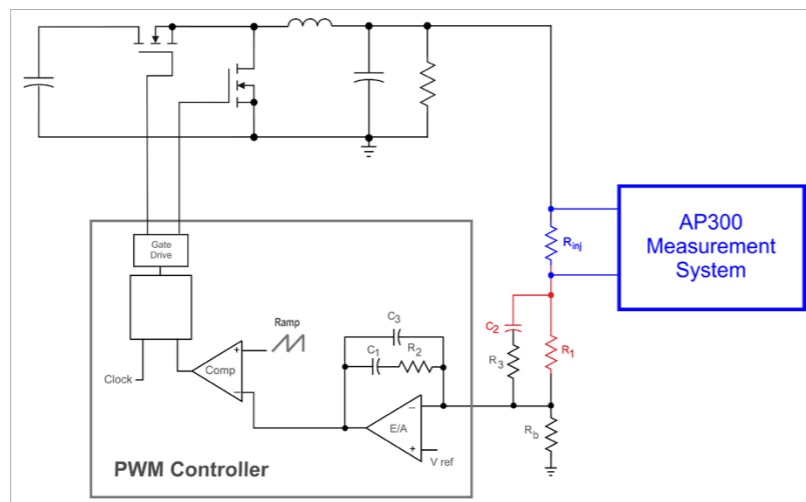

Fig. 5: Injecting Into the Loop. Components of the Feedback Must be Lifted From the Board, and an Injection Resistor Must Be Added.

application. Instead, the data sheets will give application note links where the loop gain is already measured, as shown in Figure 4.

The loop example of Figure 4 shows a high loop crossover of 55.1 kHz with a measured phase margin of 47 degrees. While this is not an unreasonable design point, it should be recognized that the crossover

points. Figure 5 shows what must normally be done to inject in the loop of the power supply. Feedback components shown in red must be lifted from the board, and the 20 ohm injection resistor shown in blue must be added, along with test leads to connect to with the measurement equipment.

If the board is laid out with

testing in mind, and the components are of a reasonable size, this test is not particularly difficult to perform, and should always be included as part of the electronics assembly development.

www.ridleyengineering.com

Summary

The loop gain and phase provides a very sensitive measure of the relative stability of a power supply when coupled with its actual load and capacitors. Skipping this measurement misses the opportunity to find errors in design and identify power supplies, which may be too close to the edge of

instability. For modern point-of-load converters, recent technological developments have increased the risk of instability as performance is pushed to the edge of the envelope, making the measurements more necessary than ever.

References

1. Step-Load Testing [29-30], <http://www.ridleyengineering.com/design-center.html>
2. Input Filter Interactions, Articles [60-62], <http://www.ridleyengineering.com/design-center.html>
3. AP300 Application Notes and Videos, <http://www.ridleyengineering.com/>

4. Engineer It: How to test power supplies – Measuring Stability (Texas Instruments Video Series) <http://www.youtube.com/watch?v=HJSaIqWzM9w>
5. Join our LinkedIn group titled “Power Supply Design Center”. Noncommercial site with over 2500 helpful members with lots of experience.
6. See our videos on loop testing and power supply design at http://www.youtube.com/channel/UC4fShOOg9sg_S1aLAeVq19Q

sps ipc drives

Electric Automation Systems and Components International Exhibition and Conference Nuremberg, Germany, 26–28 November 2013

Answers for automation

Experience at Europe's #1 platform for electric automation:

- 1,450 exhibitors
- all key players of the industry
- products and solutions
- innovations and trends

Your free entry ticket www.mesago.com/sps/tickets

More information at +49 711 61946-828 or sps@mesago.com



Energy Measurement Fulfills Promises of the Smart Grid

Flawed energy measurement severely hampers optimal energy delivery

By: Gordon Lee, Maxim Integrated

Measuring electrical power consumption—dynamic current and voltage—is a fundamental requirement of many high-precision applications like electric vehicle charging stations, industrial control and automation systems, data centers, smart home appliances, solar inverters, street lighting, distribution automation, smart electricity meters, and any future smart grid application. We cannot, in fact, emphasize enough the importance of precision energy measurement for these applications. For example, flawed energy measurement—inaccurate or even untimely—for an electrical utility severely hampers the utility's ability to successfully manage customer time of use and optimize energy delivery.

For example, there is now a reference design called Sonoma that meets the high-accuracy and low-cost needs of energy-measurement applications. This subsystem performs accurate AC energy measurement while utilizing a low-cost galvanic isolation architecture. Sonoma

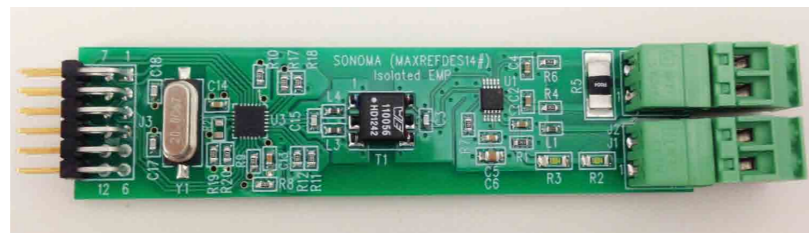

Figure 1: The reference design board, MAXREFDES14.

uses a shunt resistor to accurately sense current and voltage without a transformer. This architecture eliminates bulky transformers and a power supply, sending both data and power through the same pulse transformer. In this article we examine the hardware and development kit firmware of the new Sonoma reference design. Lab tests verify performance. We will explain why the Sonoma is so valuable for energy measurement in smart grid applications.

Leveraging Low-Cost Galvanic Isolation and Small, Integrated Sensing Resistors

Traditional AC measurement applications use bulky and expensive voltage/current transformers for sensors to step down voltage to a range that a solid-state analog-to-digital converter (ADC) can measure accurately. While extremely functional, especially in high-

voltage applications, current and voltage transformers are expensive and bulky. There are also hidden costs and design challenges that are unwelcome to engineers trying to reduce size and costs. (See the Sidebar discussion of these design trade-offs.) Alternative architectures place isolation between the measurement subsystem and the system microcontroller. These architectures require isolation of both data and power, thereby increasing the number of system components. The Sonoma energy-measurement subsystem provides galvanic isolation from the system with a single pulse transformer and uses resistors as the sensing elements. The result is a small, cost-optimized board (Figure 1).

Implementing the Energy-Measurement System

The Sonoma design utilizes an isolated energy-measurement

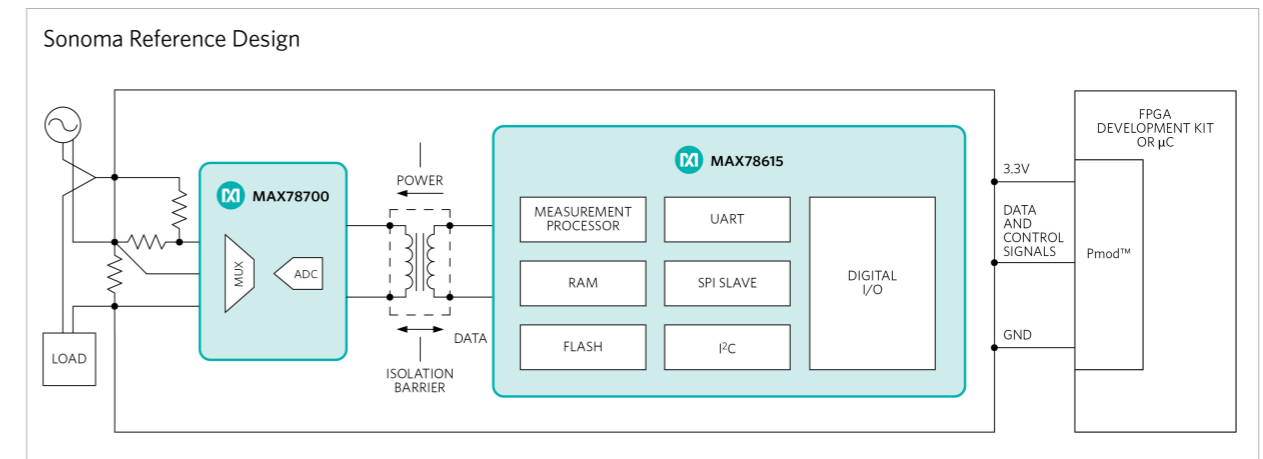

Figure 2: The Sonoma subsystem uses the MAX78615+LMU energy-measurement processor; a MAX78700 isolated, multichannel, precision ADC, a pulse transformer, an optional 20MHz crystal oscillator, and the appropriate sense resistors for converting 2-wire AC loads up to 8A.

measurement processor. Positioned in the isolated domain of the system, it simplifies integration into the existing low-voltage domains found in many embedded systems. Pages of the device's internal Flash memory are reserved for storing configuration and calibration data. Across the isolation barrier, the MAX78700 ADC connects to the MAX78615+LMU processor through a single, low-cost pulse transformer. Using unique remote sensor technology, the ADC receives timing and configuration data, and power from the processor. The ADC responds with converted data samples of the voltage, current, and die temperature. The board is configured for a SPI interface between the processor and host system (Figure 2). The design files provided with Sonoma support this mode. As an option, you can remove R10 which will

Hardware Description

Sonoma connects to Pmod-compatible FPGA/microcontroller development boards. The flexibility of the Pmod specification is important because it allows for both 3.3V and 5V modules and various pin assignments. Sonoma requires a supply voltage of 3.3V from the Pmod connector and uses the SPI pin assignments.

At the heart of Sonoma is the MAX78615+LMU energy-

measurement processor.

Positioned in the isolated domain of the system, it simplifies integration into the existing low-voltage domains found in many embedded systems. Pages of the device's internal Flash memory are reserved for storing configuration and calibration data.

Across the isolation barrier, the MAX78700 ADC connects to the MAX78615+LMU processor through a single, low-cost pulse transformer. Using unique remote sensor technology, the ADC receives timing and configuration data, and power from the processor. The ADC responds with converted data samples of the voltage, current, and die temperature.

The board is configured for a SPI interface between the processor and host system (Figure 2). The design files provided with Sonoma support this mode. As an option, you can remove R10 which will

place the device in UART mode.

The MAX78615+LMU processor contains a fixed set of preprogrammed scaling factors (optimized for a given bill of materials, BOM) in the NV memory to perform proper voltage, current, and power calculations. The resulting measurement accuracy is directly related to the initial tolerance of the passive components found in the sense circuit. The Sonoma reference design utilizes fixed-gain coefficients and offsets derived from examining 10 initial units.

LX9/ZedBoard™ Firmware Description

The Sonoma design was verified using the LX9 and ZedBoard platforms. (Project files, device drivers, and example code are currently available.) The firmware provides an interface to the MAX78615+LMU processor for register, read, and write commands. The firmware is in C and custom Sonoma-specific

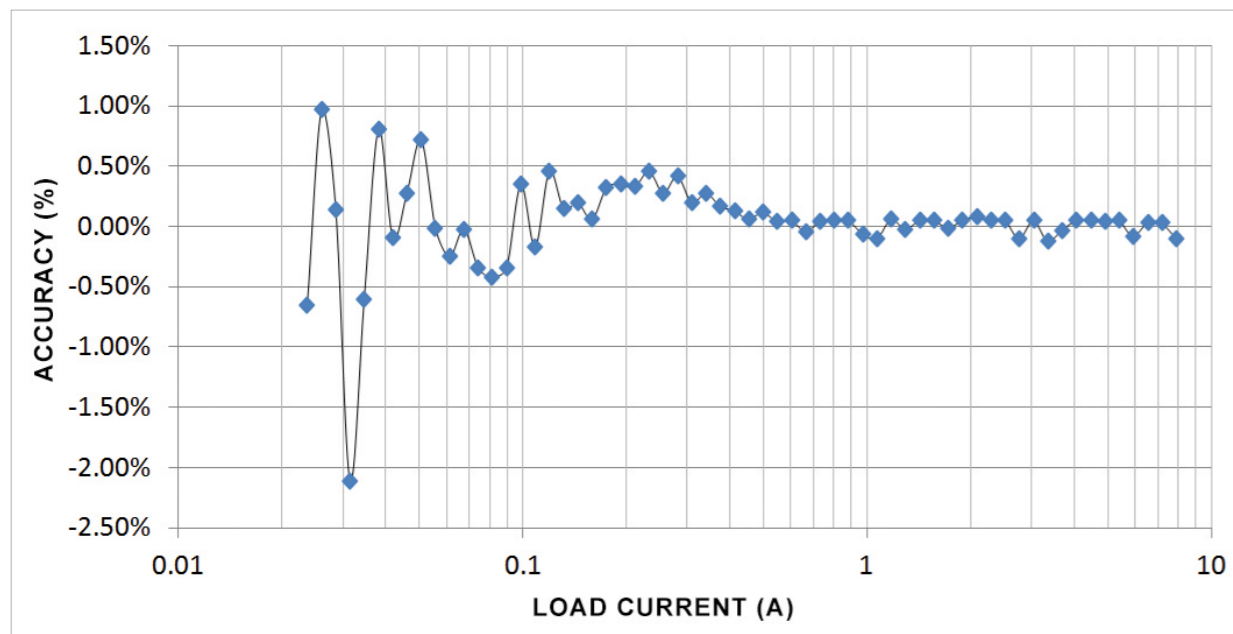

Figure 3: Detailed active power load line; power accuracy: 23.5mA to 7.9A at 120VRMS/60Hz and at room temperature.

design functions are available. The complete source code is provided to speed customer development. Additionally, the Sonoma design can easily be used by any microcontroller or FPGA development board because of the simplicity of the onboard Pmod-compatible connector.

Lab Measurements

Lab tests were performed and duplication of this test data requires an AC source with high accuracy. Figure 3 shows the measured power accuracy of a random Sonoma board over load current. The error is less than $\pm 3\%$ with a fixed set of gain/offset coefficients for the sensors. Calibration of the sensors would achieve higher accuracy. Lower current levels produce higher errors because the measurable signal is closer to the noise level.

Averaging multiple data reads or increasing the accumulation interval of the MAX78615+LMU will reduce the relative error.

Sonoma and the Smart Grid

Now let's look at smart grid applications for a moment. Energy measurement provides critical data in all locations of the electrical grid, including transmission, distribution, and consumption. Sonoma is most effective in submetering and endpoint consumption applications. For example, an electrical vehicle charging station can use Sonoma to measure the power consumption and then provide that information to the utility and the consumer for better energy usage management. The power used for charging electrical vehicles is often billed at a different rate, making it a submetering

application and requiring energy measurement to calculate the specific costs for charging.

In the smart grid, demand response (DR) enables individual customers to contribute load reduction during the peak load times. There are two primary ways to reduce peak load. First, high-energy consumption devices, such as air conditioners and pool pumps, are connected to a smart grid network with energy measurement and some form of communication added to them. Then, consumers can allow their respective utility to reduce load by actually controlling those appliances during the peak load time.⁴ Second, utilities can implement time-of-use pricing, meaning that they provide time-varying pricing to consumers. Consumers then manage their

use of specific appliances to reduce cost. All of these "smart" appliances need a device like Sonoma to learn the energy consumption of each appliance so the utility can calculate the associated energy cost.

Challenges for Designing with Voltage/Current Transformers

If isolating at the sensors, one must use two transformers (current and voltage) which are bulky. The AC wiring in and around these transformers consumes space as well. The benefit here is that there are no isolated power requirements nor need for optoisolation of the data lines.

If a design is only using a current transformer or a shunt, then one may need a nonisolated power supply. This often adds a power domain to the design plans. There are multiple ways to accomplish this, but it always involves a capacitor and/or transformer that require more space. For data isolation, the optoisolators use considerable space because of the larger lead-pitch package options needed for AC voltage levels. Knowing how many traces to isolate and at what speed makes the costs highly variable as well. For example, someone may plan to isolate two lines (RX/TX), but later need a digital IO isolated as well for an alarm function. Finally, the nonisolated power must scale with the optoisolation as well. (Isolating high-speed SPI, for example, consumes a decent amount of current, which may increase the

cost/size of the nonisolated power supply.)

Using Sonoma, everything is bounded. Size and costs are known at the outset and there are no special power-supply requirements nor a need for optoisolation of the data lines.

The Sonoma reference design will be especially beneficial because of its smaller size. With data and power isolation achieved using a single pulse transformer, the traditional bulky transformers and an isolated power supply are no longer needed. The high integration reduces the size and cost of Sonoma, relative to other accurate energy-measurement solutions. The preloaded and upgradeable firmware is adaptable to existing setups and greatly simplifies design time.

To many consumers the smart grid means a smart meter connected to their residence. However, the smart grid consists of many more applications than just smart meters. Some of these applications are yet to be discovered and will provide tremendous benefits in the reduction and optimization of energy consumption. In all cases, energy measurement must be part of the system. Reductions in size and system cost, as implemented in Sonoma, will further drive adoption of accurate energy measurement into the smart grid of today and tomorrow.

www.maximintegrated.com

Dawn of a new intelligence for current measurement

SPS/PC/Drives Hall 3.666

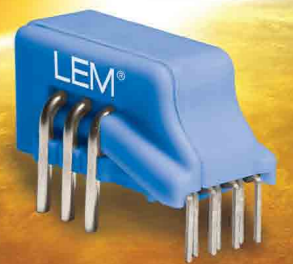

HO

Conventional current transducers are over. The age of intelligent, interactive transducers begins with the dawn of the programmable HO. Set its operational characteristics using a simple microcontroller interface to meet your applications' needs. Its outstanding performance gives you better control and improves the efficiency of your system whilst minimising inventory with one configurable device.

The future starts now!

- Three programmable ranges: 8 A_{RMS}, 15 A_{RMS}, 25 A_{RMS}
- Single +5V or +3.3V power supply
- Through-hole and SMT packages
- Up to 8 mm creepage and clearance distances + CTI 600 for high insulation
- Half the offset and gain drifts of previous generation
- Overcurrent detection with programmable thresholds
- Programmable slow (6 μ s) or fast (2 μ s) mode
- Up to 4 programmable internal reference voltages
- Access to voltage reference
- -40 to +105°C operation

www.lem.com

At the heart of power electronics



Normally-Off and Current Collapse Free by Unique GIT Technology Realize Commercialization of GaN Transistor

Creating MOS alternative devices to address the needs of advanced power systems

By: Howard Sin, Panasonic

For more than thirty-five years, the power MOSFET dominated the power management systems due to its constant technological evolution from its device structure to its applications to circuit topologies. However, at the dawn of the new millennium, power MOSFET reached its theoretical limitations that it became unable to cope with the advancement of new power supply and power management system designs. Current trends of power supply design, both for industrial and commercial applications focus on higher efficiency and increased power density that are beyond the capability of MOS technology. This lead design engineers to look for MOS alternative devices that will be able to cater the needs of the modern power supply and power management systems. This is the start of the conception of Gallium Nitride (GaN) transistors.

Early GaN transistors were introduced in the early 2000's. With its promising capabilities and characteristics in high-speed and high-frequency applications, a very low on-resistance and a very high breakdown voltage, GaN is touted as the next generation power semiconductor. GaN has the characteristics necessary to increase the power density of up to hundreds of watts per cubic inch and the ability to propel the power supply efficiency to the higher level. Ordinary MOSFETs do not possess these characteristics.

The introduction of GaN devices opened to the idea of fast switching and more efficient power supply circuit design.

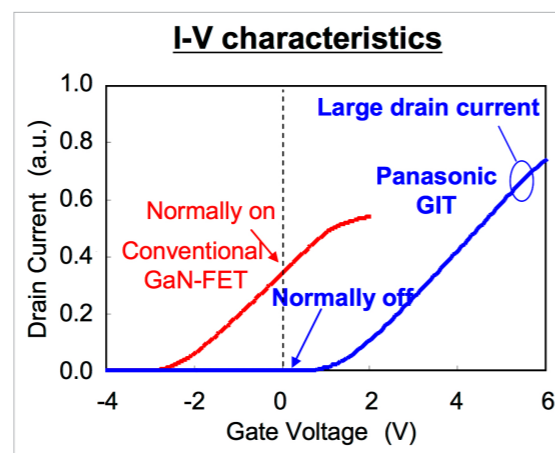

Figure 1: I-V Characteristics of Normally Off GIT GaN and Conventional Normally On GaN

Normally-on conventional GaN with I-V characteristics as shown in Figure 1 were initially developed. However, commercialization of this first generation GaN transistor was almost impossible due to an unwanted characteristic of the device during operation. A conventional GaN transistor operates in a normally-on condition where the device does not shut down even when there is no gate voltage applied. This

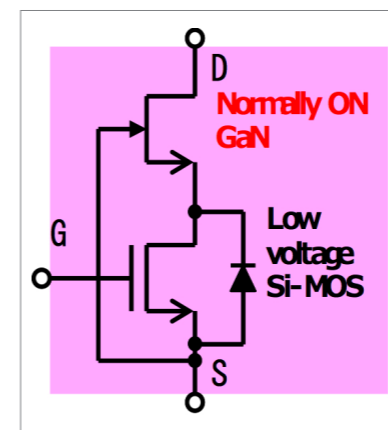

Figure 2: Cascode Structure of Normally On GaN with Low Voltage Si-MOS for pseudo-Normally Off Operation

raised safety concerns from the design engineers. Normally-on GaN requires a negative voltage to switch to an OFF state. With few options, manufacturers developed a countermeasure to transform normally-on GaN transistors to normally-off in order to enable the use of GaN in power circuits. This countermeasure is in the form of a cascode structure, as shown in Figure 2, where a standard low voltage Si-MOS with a normally-on GaN is packed into a module or multi-chip to achieve a pseudo-normally-off operation.

Panasonic, on the other hand, has a different story to tell. Using its novel Gate-Injection Transistor (GIT) technology fabricated on a Si substrate as shown in Figure 3, The company was able to develop a true normally-off GaN that does not need an additional Si-MOS or cascode module to complicate the device structure. Panasonic was able to develop a single GaN transistor with a very high

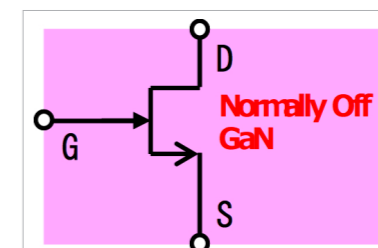

Figure 3(a): Single Normally Off GIT GaN Device

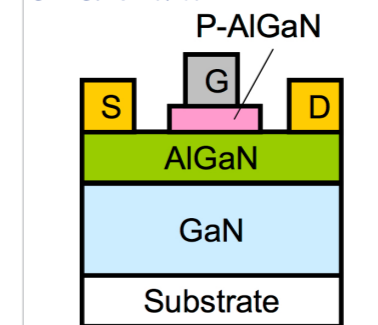

Figure 3(b): P-type AlGaIn for Gate Electrode in Normally Off GIT GaN Structure

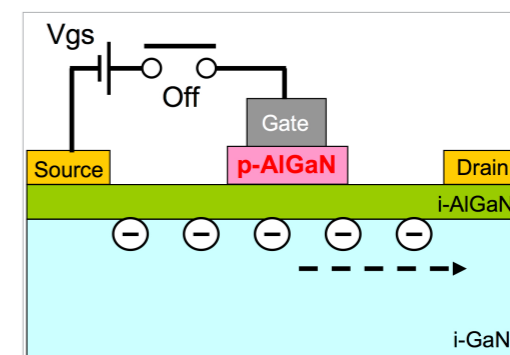

Figure 4(a): Electron Depleted in AlGaIn/GaN Interface during Zero Bias

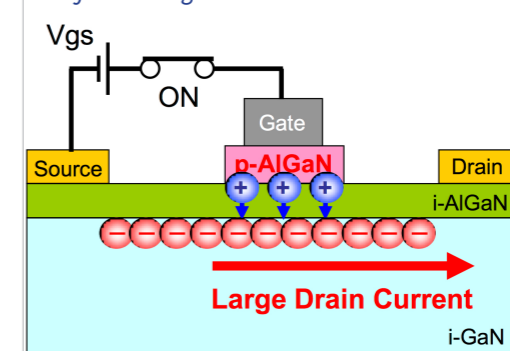

Figure 4(b): Conductivity Modulation when VGS > Vth

reliability in a single package.

The GIT structure employs P-type AlGaIn as the gate electrode. At zero gate-source voltage bias, the electrons at the channel deplete in AlGaIn/GaN interface as shown in Figure 4(a). Drain current cannot flow in the transistor when there is no gate-source voltage injected. This shows a typical characteristic of normally-off operation, which is also similar to that of conventional Si-MOS. When a gate-source voltage that is higher than the threshold voltage is applied as shown in Figure 4(b), holes from the P-type AlGaIn are injected into the channel by conductivity modulation. This generates an equivalent amount of electrons

in the channel. The generated electrons that flow into the drain electrode increase the drain current. Since the effective mass of holes is 100 times larger than that of electron, the injected holes stay around the gate and allow electrons to increase to approximately 100 times of their normal amount. By this phenomenon, the resistance of the transistor drops dramatically.

These high mobility electrons that occur between the interface of AlGaIn and GaN

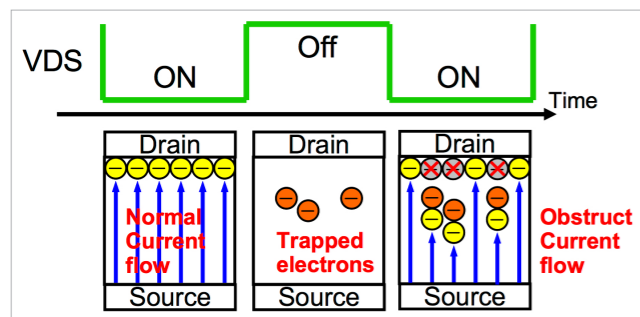

Figure 5: GaN Electron Trapping during On/Off Switching Leading to Current Collapse

contribute also to the high switching speed. Therefore, by using a P-type AlGaIn gate of GIT and by taking advantage of the conductivity modulation through holes injection from the gate electrode, a genuine normally-off operation is achieved and on-state resistance is reduced dramatically.

The earlier adoption of GaN transistor was mainly for low-voltage applications. It was almost impossible to adopt GaN transistor to high voltage application because of a GaN device natural phenomenon called 'current collapse', which occurs when the GaN on-resistance increases during the application of high voltage to the device. This is believed to be caused by trapped electrons in a high-electric field. However, the detailed mechanism that causes current collapse is still unknown and is still in the infancy of research.

Current collapse can be illustrated in switching cycle using Figure 5. During the first ON state of the GaN device, the

current flows normally after the formation of the channel. When the device is turned OFF in the next state, some electrons

electric field at the edge of the drain-gate side. The increase of on-resistance can degrade the efficiency of application, heat up the device and finally destroy the device irreversibly. This poses high safety risk on high voltage applications.

To prevent current collapse and to ensure safety operations

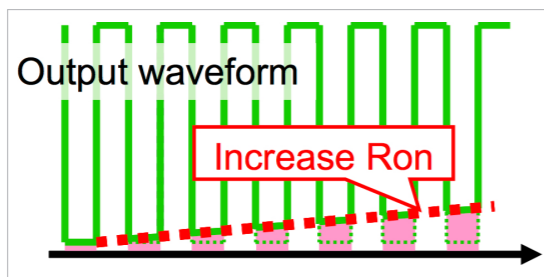

Figure 6: Increasing Ron during the Current Collapse of Conventional GaN

remain trapped in the channel hereby creating 'trapped electrons' that would eventually obstruct the smooth current flow. During this phenomenon, on-resistance increases continuously as the power device keeps on switching ON and OFF as shown in Figure 6. This phenomenon gives rise to the term of dynamic on-resistance or transient on-resistance. Electron trapping

occurs at the interface between GaN and AlGaIn when high voltage is applied. The increased amount of electron depends on

of GaN at high voltages, Panasonic uses novel technology to decrease the trap density by modifying the fabrication process. Moreover, crystalline quality of GaN is improved

and a transistor structure that could reduce the electric field is adopted. As shown in Figure 7, the normally-off GIT GaN is tested up to 800V. Tests show that even at 800V the functions of the device was not degraded and the on-resistance did not increase unlike the conventional GaN structure. This is tantamount to a Current Collapse Free GaN transistor. This makes

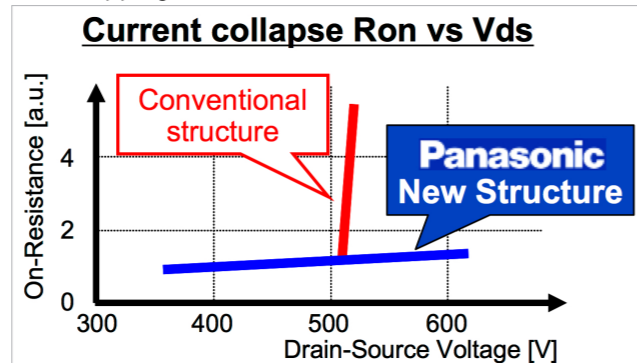

Figure 7: Increasing Ron during the Current Collapse Comparison

the Panasonic GaN suitable to use in continuous worry-free operation even at high voltage applications.

The lateral structure of the GIT also provides some advantages for high speed switching owing to the lower parasitic capacitance of the structure than that in conventional Si-based power transistors with the vertical structures. RonQg (Ron: on-state resistance, Qg: gate charge) is a figure-of-merit for high speed switching. The fabricated normally-off GIT GaN exhibits low RonQg of 715mΩnC, which is one thirteenth lower than that

of the state-of-the-art Si MOS transistors. This only shows that the potential of the lateral structure is superior. The device potential is demonstrated in a 1MHz operation of resonant LLC DC-DC converters at high efficiency over 96% (1kW output). This demonstration indicates that the presented GIT on Si can be used for practical systems, free from the operation failure. Moreover, due to the similarity of operation as Si-MOS, this know-how can be applied easily when using normally-off GIT GaN.

With its novel technologies, Panasonic is able to offer

high reliability and safety GaN transistor with a true normally-off and a current collapse free even at high voltages. Panasonic GaN transistor is the first in the world to be able to achieve stable operations up to 800V with the suppression of the increase of on-resistance during continuous switching operation. Panasonic GaN is expected to enhance power density and more energy savings of power supply and power management systems through more efficient and faster operations.

www.panasonic.com

APEC® 2014

March 16–20, 2014

Fort Worth Convention Center
Fort Worth, TX

THE PREMIER
GLOBAL EVENT
IN POWER
ELECTRONICS™

Visit the APEC 2014 web site
for the latest information!

www.apec-conf.org

SPONSORED BY



High-performance resistors in custom power supplies

Using resistors in power supplies presents a multitude of differing performance requirements

By: Phil Ebbert, Riedon

The subject of power supplies is potentially very broad and the application of resistors in power supplies is quite diverse. Here we will focus on power supply units (PSUs) designed for use in electronic appliances that nominally require fixed DC outputs ranging from just a few volts up to a few kV.

Whether such end-equipment is destined for consumer, commercial or industrial markets, the PSU designer will need to pay heed to stringent safety, environment and other regulations in addition to meeting the basic electrical performance requirements. As well as considering the role of resistors in regulating a power supply's output voltage (or current), we will examine how resistors protect a supply from potential fault conditions, such as output overload, output short- or open-circuit and input surge currents, which can result in a fire or present a shock hazard to users.

Power supplies are often defined by their input source, AC or DC,

and whether they use linear or switched mode regulation to achieve the desired DC output. AC/DC supplies are typically line powered but a DC in, DC out supply could just be a linear circuit that regulates the output from a battery or other DC source to produce a lower DC level. The term DC/DC converter is usually reserved for supplies that use switched-mode techniques, which can support both step-down (buck) and step-up (boost) conversion for lower and higher voltages respectively.

While most power supply manufacturers offer a range of standard units to satisfy various end-equipment requirements, some applications demand a custom solution. As a manufacturer and supplier of high performance resistors, Riedon has the experience to help designers choose the right component.

Back to basics – simple linear regulators

Understanding some of the basics of power supply design would seem a good way to appreciate the importance of seemingly

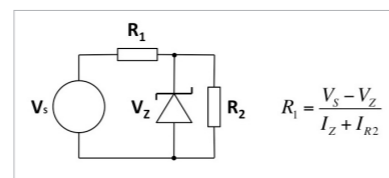

Figure 1: A simple Zener regulator circuit

mundane components like resistors. From their college days, most engineers will remember designing Zener regulators to provide a constant voltage to a permanently connected load, represented by R2 in **figure 1**. The principle is straightforward and simply requires the value of R1 to be calculated to provide both the minimum current needed to ensure the Zener diode operates in its constant voltage breakdown region, as well as the full load current.

Zener regulators are generally fine for low power applications where both the supply voltage and load are reasonably constant. However, in a shunt configuration like this, a significant reduction in load current or increase in supply voltage may result in an increased current through the Zener diode that exceeds its maximum power dissipation. From the resistor

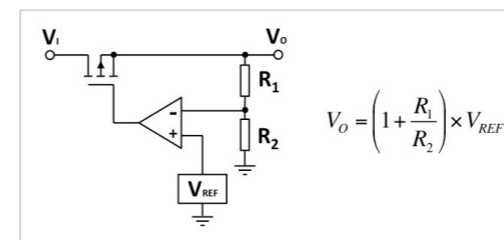

Figure 2: Simplified diagram of a linear series regulator

perspective though, other than the power rating needed to handle the combined load and Zener currents, the performance requirements on R1 are minimal.

Greater sophistication in linear regulation is achieved with a series design that uses a pass transistor to regulate the load current and drop the input voltage to the required output level. This concept is shown in **figure 2** and such designs are typical of integrated circuit (IC) regulators and also low drop-out (LDO) regulators, which often provide a regulated supply at the “point of load”.

The potential divider formed by resistors R1 and R2 is used to sense and set the output voltage relative to an accurate reference voltage. In the case of fixed output linear regulator ICs this divider will be internal but, for other regulator ICs and PSUs, having one or both arms of the voltage divider external to the device provides the necessary flexibility to adjust the output voltage as required.

The choice of resistor values for the divider chain is primarily determined by their ratio, so a key consideration is their impact

on total power supply accuracy. Provided that the comparator circuit has a high gain and high input impedance, the effects of resistor tolerance can be calculated by modeling their worst case value

in the output voltage equation above, e.g. calculating first with R1 at its maximum value and R2 at its minimum and then vice versa to find the potential deviation in output voltage.

To illustrate this: If VREF is 1.2V and R2 is nominally 5kΩ then for a 3.3V output R1 needs to be 8.75kΩ. So if R1 and R2 are 1% tolerance devices the worst case output error is ±1.27%. However, the output error is reduced for an output voltage closer to the voltage reference e.g. for a 1.8V output R1 needs to be 2.5kΩ and the output error is ±0.67%. These errors due to resistor tolerance add to the rated accuracy of the device itself, so if the device is nominally specified to ±1% then it is usually desirable that the error due to resistor tolerance is not significantly greater.

Switching technology improves PSU efficiency

Because linear power supplies divide the DC source to provide a regulated output voltage, energy is being consumed in the series pass device as well as the load. This results in low efficiency, especially if the voltage dropped by the regulator is significant.

A switched-mode power supply (SMPS) takes an unregulated DC source, which may be from an AC line input that has been directly rectified and smoothed, and switches it on and off at high frequency (typically 10kHz – 1MHz) with a duty cycle that determines the resulting DC output voltage, once that high frequency AC signal has been rectified and smoothed. Output regulation of an SMPS uses a similar output sensing arrangement to the linear series regulator described earlier but now the feedback signal from the potential divider is used to control the switching frequency and duty cycle.

By avoiding the voltage dropped by a linear regulator that continually dissipates power, a switched-mode supply, where the pass transistor is either fully on or fully off, achieves much higher efficiency, which in good designs can be up to 95%. What's more, compared to a linear AC-DC supplies of similar rating, switched-mode supplies will be much smaller because the high-frequency transformer (typically required to provide electrical isolation from the line input) and associated filter/reservoir capacitors, are physically smaller than the equivalent components in a linear supply.

However one issue with switched-mode supplies is that they require a minimum load to operate correctly and can be damaged under no-load conditions. For this reason it is not uncommon to build in a dummy load in the

form of a suitable power resistor that will draw the minimum specified load current in the event that the primary load becomes disconnected. Of course, such a load resistor will itself consume power, which not only needs to be taken account of in the resistor specification but also reduces the efficiency of the supply. An alternative solution is to employ a shunt resistor that can be connected across the output to divert current should the power supply detect that the intended load has gone open circuit. Switched-mode supplies usually include other safety features such as current limiting to protect against output short-circuit and shut down the supply. Low ohmic value, high-power shunt resistors can also be used in a similar crowbar fashion to protect users from over-voltage conditions.

DC-DC converters also use switching technology to convert from one DC voltage to another. Indeed the step-down form of DC-DC converter (often referred to as a “buck” converter) essentially operates in the same way as a SMPS. Step-up, or “boost”, DC-DC converters use charge pump techniques to raise the input voltage to a higher output level. In general though, the same methods of regulating the output voltage still apply along with similar techniques for protecting against fault conditions.

Further roles for resistors

In addition to their use for voltage

sensing/setting and as dummy loads or shunts, resistors can play a number of other important roles in power supply designs:

- Bleed resistors placed in parallel with a power supply’s load are used to discharge the smoothing capacitors used in linear AC-DC converters and also the reservoir capacitors employed by DC-DC converters. These capacitors can retain charge long after a supply is turned off, presenting a potentially lethal shock hazard to users accessing the supply. Clearly the bleed resistor’s value should be calculated to be high enough not to consume significant power when the supply is operating normally but low enough to discharge the unit relatively quickly when the supply is switched off.
- Inrush limiting resistors of a few Ohms or less in series with the AC line can address the problem with AC-DC converters where a large surge current may occur at switch-on as the bulk storage capacitor is initially charged. The alternative, particularly for higher-wattage supplies, is to use negative temperature coefficient (NTC) resistors, which initially present a higher resistance that falls as their temperature increases through self-heating. But, to ensure an acceptably low resistance value during normal operation, NTC resistors have to continue operating at

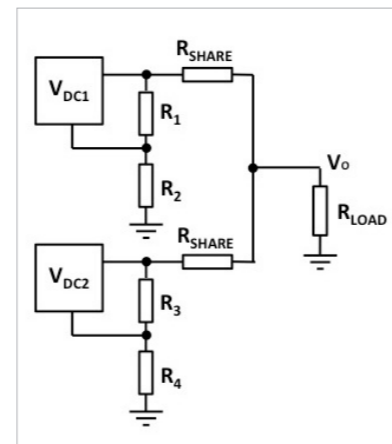

Figure 3: Balancing resistors share load between DC-DC converters

this temperature, which may be incompatible with other constraints on the power supply’s operation. The use of specialized pulse withstanding resistors may be a better solution – these are rated according to their energy-handling capacity in Joules rather than the continuous power rating (in Watts), which the high inrush current level would otherwise dictate.

- Balancing resistors provide a way for sharing a load either between two or more DC-DC converters. Operating DC-DC converters in parallel may be more cost effective than using a single higher-current unit or may be more desirable in some instances because of physical size constraints or thermal considerations. However simply tying the outputs of two converters together does not ensure they share the load current equally. The equal value RSHARE resistors shown in figure 3

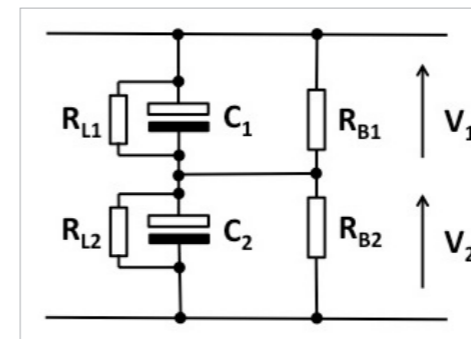

Figure 4: Balancing resistors ensure equal voltages across output capacitors

accommodate the difference between the regulated outputs of each converter.

A similar situation applies to the power transistors used to regulate the load in various power supply designs. Rather than using a single device rated at the full load it may be better to use several transistors in parallel to share the load. So, as with the paralleled DC-DC converter, load-sharing resistors can be placed in series with the output of each transistor to equalize the current.

A third balancing scenario is encountered where reservoir capacitors are connected in series to the outputs of high voltage DC supplies, as shown by C1 and C2 in figure 4. The problem here is that electrolytic capacitors have leakage currents that can be considered as resistors in parallel with the capacitor. Unfortunately these leakage resistances (RL1 and RL2) can differ significantly in value, even for the same value capacitors, but they act as a potential divider across the output resulting in unequal voltages

across the capacitors, which could exceed their maximum rating. A solution is to add more accurately matched, lower value external resistors (RB1 and RB2) across the capacitors to counteract the leakage effect.

Important points:

- High voltage dividers are used to scale down the output of a high voltage power supply to provide feedback for regulation purposes and potentiometric ratios as high as 1000:1 are not uncommon. Voltage divider resistors are also used in applications such as automatic defibrillators to monitor the high voltage supply used to charge the storage capacitor and switch the supply off once the required charge level is reached.
- High current sensing is where a low ohmic precision resistor is used in series with the supply current to measure current by measuring the voltage it drops, using the principle of a shunt ammeter. The dilemma facing the designer is the conflict between minimizing heat generation and power loss ($P=I^2R$) by choosing a low resistance, versus a higher resistance that results in a larger voltage drop, which is easier to measure.

www.riedon.com



EMPOWERING GLOBAL INNOVATION

CHINA : NORTH AMERICA : EUROPE

WWW.POWERSYSTEMSDESIGN.COM

From Search to Samples in Seconds



Our web tools help you quickly pick the perfect inductor.
Then get free samples overnight!

We make picking inductors fast, easy, and almost fun!

Start with a quick parametric search for parts that meet your specs. (We even show you volume pricing.) Click to instantly compare core and winding losses for multiple inductors.

Want to see actual L and I

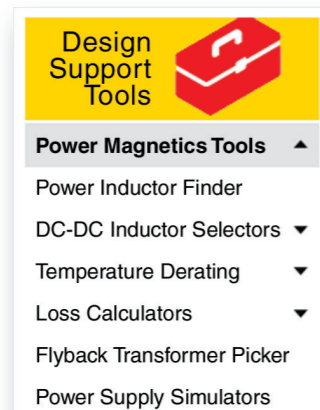

curves at a specific temperature? There's a tool for that!

When you've picked your inductors, just click to get free samples. Do it by 5:00 p.m. CST and they'll ship to you the same day!

See how fast *you* can go from search to samples. Visit coilcraft.com/tools



WWW.COILCRAFT.COM



Special Report: Solar and Wind Electronics



INSIDE:

Predicting the Grid...

28

SiC poised to revolutionize solar power inverters...

31

Italian project delivers zero-emission power from biomass...

34

Nanopower energy harvesting dramatically extends battery life...

38

Supercapacitors enable energy harvesting in space-constrained apps...

43

Predicting the Grid

Using the next-generation of sensors and analytics to manage the Smart Grid

By: Edward H. Kennedy, Tollgrade Communications

From the North East blackout of 2003 to last year's Super Storm Sandy, we've learned the hard way that our 100-year-old-plus electricity grid is lacking the intelligence to effectively respond to power outages and disturbances. Here are a couple of key points to consider that call out for the need for a paradigm shift in the way we think about the grid to successfully improve reliability.

Unmonitored distribution

First, there are millions of miles of unmonitored electricity distribution and subtransmission lines that are responsible for delivering power to businesses and residential customers. The unmonitored distribution network is also where most of the world's outages occur and they are on the rise. For example, electric disturbances in the U.S. have seen a dramatic 265% increase in the raw number of major outages occurring since 1984 with an annual cost as high as \$188 billion to the U.S. alone. In North America, our distribution grid is the largest part of a utility's network, spanning over six million miles and is estimated to be eight times larger than transmission. And, according to the Edison Elec-

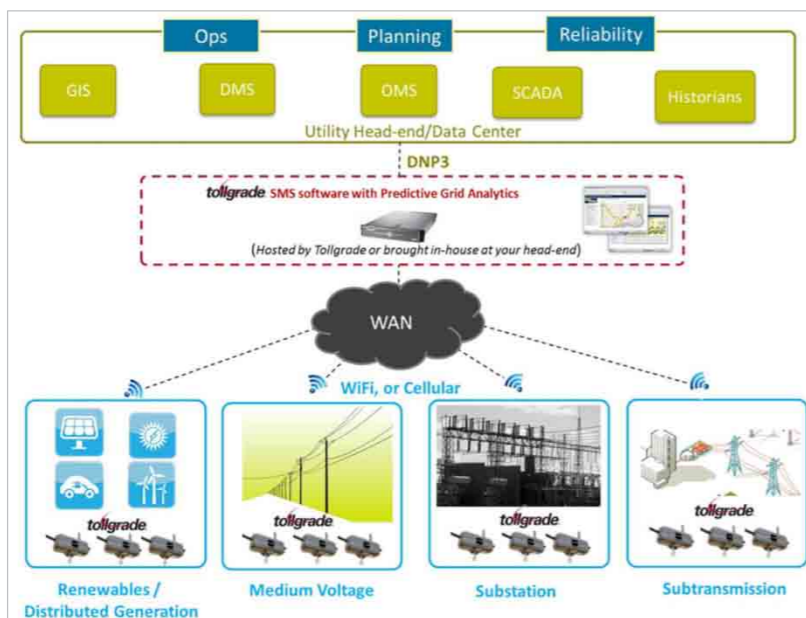

Figure 1: Sensors installed on power lines communicate real-time grid health data.

tric Institute (EEl), it's also where 90% of the outages occur.

Aging infrastructure

Second, our grid is an old and aging infrastructure. In the U.S. its estimated 70% of transformers are over 25 years old and quickly approaching their end of life, while in extreme heat and weather, many are being stressed well beyond their productive limits. This aging, stressed infrastructure also contributes to more outages as failing equipment causes an estimated 25% of outages. With the DOE projecting summer peak demand

to increase by almost 20% during the next 10 years and demand expected to double by 2050, many believe we have an opportunity now to make investments to modernize our grid to avoid some of the worst case scenarios being prophesized now.

Grid dependency

Finally, it is a fact that our modern economies, and GDP, are becoming more "grid dependent." When a factory has to shut down because of a power quality issue, it costs businesses in the U.S. as much as \$25 billion dollars a year, accord-

ing to the Electric Power Research Institute (EPRI). With better, real-time monitoring, utilities will be able to deliver the power quality required for today's modern economy.

All of this requires monitoring of the medium voltage grid. To monitor this entire distribution network, utilities need more than smart meters. They need smart-grid sensors that are inductively powered, can provide visibility to low amperages, and can integrate with wireless systems to transmit real-time grid health data back to the utility back-office for additional analysis, trending and alarming. Now, with more affordable and flexible communication options including Wi-Fi, WiMAX and cellular, this vision is a reality. These Wi-Fi or Cellular sensors can be installed in minutes and can span the millions of miles of unmonitored power lines from the substation to sectionalize feeders and communicate real-time grid health data back to analytics software, which alerts utilities to problems for faster resolution (Figure 1).

Tollgrade Communications is the first to market with this type of an integrated offering. With a global footprint and over 25 years of experience in providing cutting-edge network assurance solutions, Tollgrade has built a reputation for improving the reliability and operational efficiency at the world's largest utilities and telecommunications providers, helping them to reduce customer down time,

modernize their networks, reduce their carbon footprint, take on new sources of renewable energy, and recover lost revenue (Figure 2).

Tollgrade provides the only solution that takes their smart grid

sensor data through four layers of analysis to build a foundation for Predictive GridSM analytics. This is a critical requirement to improve overall accuracy and effectiveness of grid data. For example, in head-to-head field trials, older generation Fault Current Indicators (FCIs) created as many as four false alarms to every true outage event confirmed by Tollgrade. False posi-

tives are detrimental to utilities, especially as they integrate the data from smart grid sensors and FCIs with other back-end systems such as Data Historians, Outage Management Systems, and Distribution Management Systems. Tollgrade offers the advantage that as the LightHouse SMS software "hands-off" this data, it can be trusted (Figure 3).

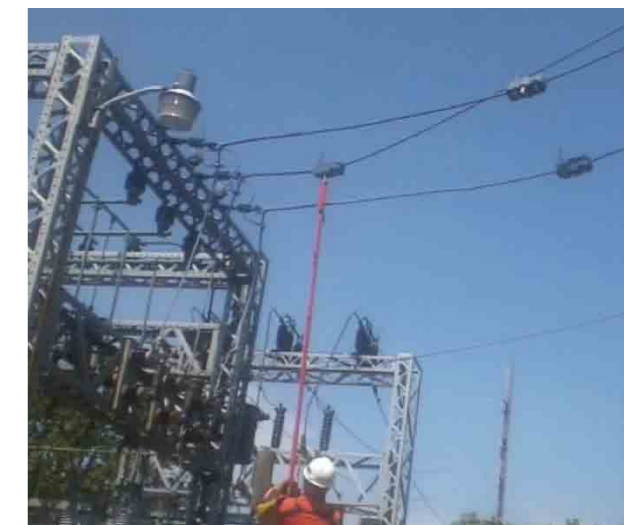

Figure 2: Improved oversight enhances reliability and operational efficiency



Figure 3: Multiple layers of analysis improve overall accuracy and effectiveness of grid data

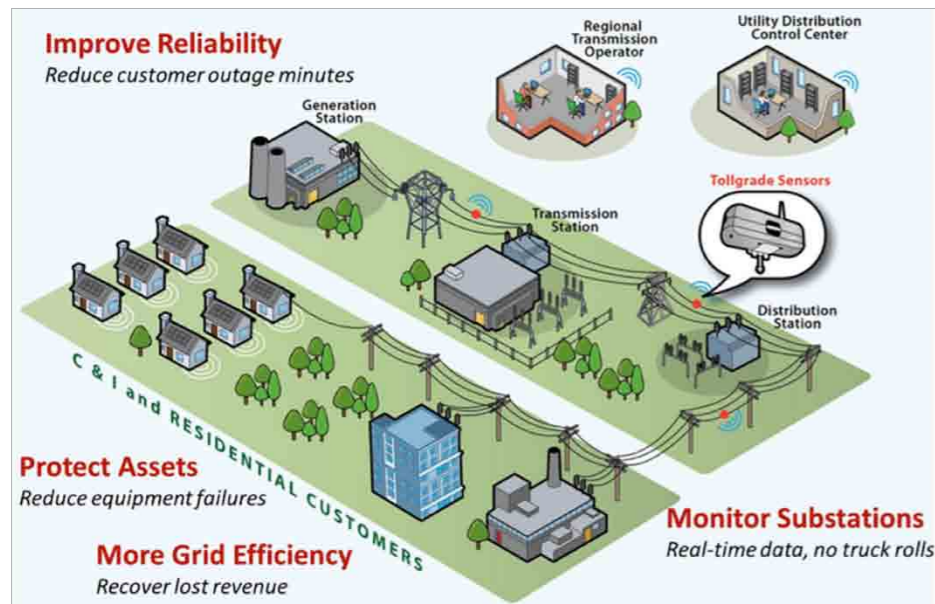

Figure 4: The ability to pinpoint the locations of problems enables quick response and resolution

Our rules-based, predictive analytics database takes advantage of waveform signatures that hold the clues to how outages and power quality events could be better handled in the future. This signature model has worked in other industries like the computer security industry, but has not been attempted before to improve grid reliability. By providing four layers of analytical processing, the software accurately detects and classifies faults that cause outages in real-time for example, permanent faults on main feeders and blown fuses on laterals. They can also detect troublesome power quality events like momentary outages. This enables utilities to perform outage restoration faster because they know more about the fault and how to repair it. For example, in two very large deployments in North America, the solution is

detecting blown fuses on laterals 20 – 30 minutes before customers call to report the outage. All events are linked to map-view displays that make it easy for utilities to pinpoint the locations of problems for quick response and resolution (Figure 4).

By having a library of power quality and outage events combined with load planning data in one software package, utilities have the situational awareness they need to react to grid changes and faster. We believe one day they'll even be able to predict future problems before they occur. The software is also customizable and over-the-air upgradable – allowing the solution to grow and evolve as utilities face 21st century challenges and applications.

While this may sound futuristic,

think back to the cell phone you were using just 5 or 10 years ago compared to the type of powerful technology you now have at your fingertips. The types of technologies utilities are beginning to embrace are putting them on a similar path from their current-state toward a future, predictive grid. A number of the world's leading utilities, including Duke Energy and CenterPoint in the U.S., Toronto Hydro in Canada and Western Power

Distribution in the United Kingdom are leading the charge with the deployment of smart grid Sensors. For example, Toronto Hydro, the largest municipal electricity distribution company in Canada, eliminated 550,000 customer outage minutes with sensors operating on two feeder lines alone.

Ivano Laboricca, their vice president of asset management said, "From an asset manager's perspective, this technology will allow us to know immediately if there is a problem that is easy to fix or if it is a serious problem that requires capital investment." For utilities, data from smart grid sensors is unlocking new possibilities from a network that was once hidden to them.

www.tollgrade.com

SiC poised to revolutionize solar power inverters

Silicon Carbide delivers higher efficiency at higher frequencies with 4X the power density of conventional silicon IGBTs

By: Jeffrey Casady & Paul Kierstead, Cree

Silicon carbide (SiC) power semiconductor technology has now reached a point in its evolution where SiC power devices can serve as the catalyst for a new generation of ultra-efficient power electronics systems, especially in the emerging market for small-to medium-sized solar power inverters. Several component manufacturers already offer a comprehensive portfolio of discrete SiC power MOSFETs (metal-oxide semiconductor field-effect transistors) and Schottky diodes, and the subsequent introduction of all-SiC integrated power modules – a form factor familiar to power electronics design engineers – has demonstrated the potential to revolutionize solar inverters by enabling the design of smaller, lighter, and higher-efficiency units for three-phase power conversion than can be achieved with conventional silicon technology. This development, in turn, can lower the overall system costs for solar energy and thus encourage more widespread commercial and residential installations.

SiC's electrical properties

As a compound semiconductor material, silicon carbide has a wider bandgap, higher thermal conductivity, and a much higher breakdown voltage than silicon (Si), which enables it to outperform silicon devices in high voltage switching applications. Since IGBTs (silicon insulated gate bipolar transistors) experience significantly higher switching losses as operating frequency increases, design engineers are forced to over-specify silicon devices (at higher amperage ratings) and/or to lower the operating frequency of their system to mitigate the Si IGBT's switching losses, consequently reducing overall system efficiency.

SiC MOSFETs have inherently better switching efficiency at high frequencies and high voltages, in addition to significantly better thermal performance. As such, SiC power devices can achieve



Figure 1: Cree's 1200V-50A 6-Pack Module

power densities and switching frequencies that are just not possible with conventional silicon components.

Replacing silicon devices with SiC power module boosts inverter output from 10kW to 40kW. The paradigm change potential of SiC power technology is demonstrated by the following example, in which a 10kW solar inverter from one of the leading manufacturers was retrofitted with a Cree SiC MOSFET module (Figure 1) replacing the incumbent silicon power module to determine how these advanced power switching devices could significantly increase delivered power while maintaining equivalent system physical form-factor.

SiC simplifies inverter topology

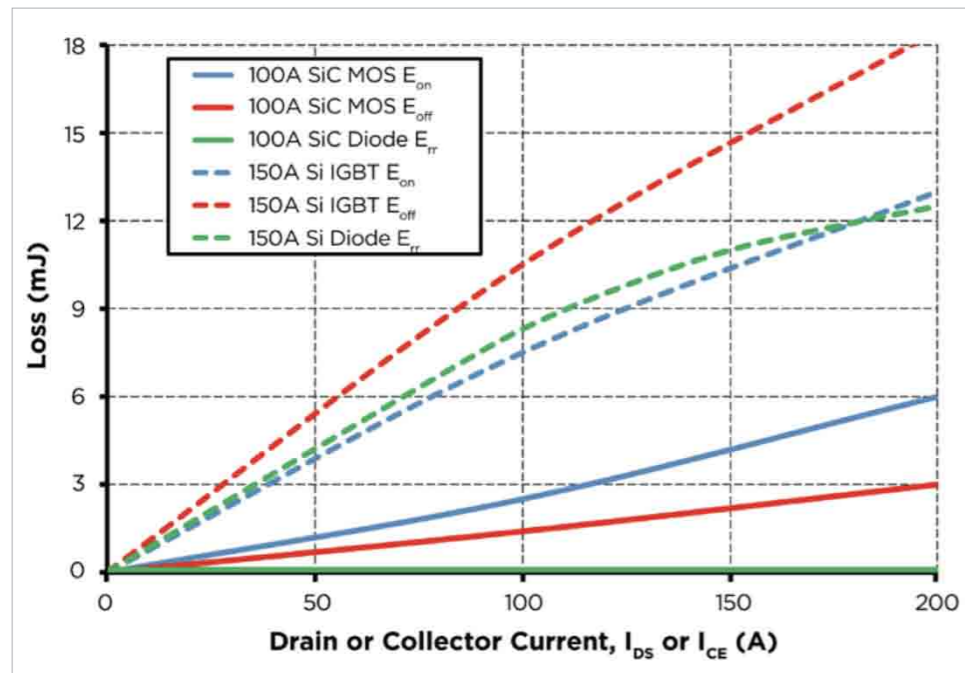

Figure 2: Switching losses for 150A Si IGBT and 100A SiC MOSFET at 150°C

The existing solar inverter unit employed a silicon-based power module of the same housing shown in Figure 1 that combined 600–650V Si super-junction MOSFETs for high frequency switching and 600–650V Si IGBTs for low frequency switching, reflecting the frequency limitations of Si IGBTs. The silicon module utilizes a relatively complex topology and control scheme to produce 10kW of power with a modest efficiency performance of 98.1% for the overall system.

Replacing the Si devices with a SiC MOSFET module rated for 1.2kV/50A in an integrated three-phase, hard-switched configuration significantly simplified the topology, as SiC components are much smaller than comparable silicon devices.

Consequently, they enabled much more power in a full three-phase configuration. The SiC module allows generation of 40kW at twice the frequency and while maintaining similar losses versus the original 10kW silicon-based device. The result is 4X the delivered power in the same physical form-factor as the incumbent silicon system. What follows are the key design optimizations enabled by SiC device advantages.

SiC's lower switching losses

Since the SiC MOSFET module exhibits considerably lower switching losses than the Si devices (as shown in Figure 2), it was possible to increase the inverter's switching frequency from ~20kHz up to 48kHz. Filter elements are critical components of any solar inverter that ties

into the utility grid. The passive inductors and capacitors required to design the line filters are inversely proportional to the ripple frequencies of the power conversion electronics and are essential to shrinking the size, weight, and cost per delivered watt in the SiC based solution. The higher frequency operation enabled by the SiC switching devices reduced the

relative volume and weight of the inductors required for the output power. As a result, the 40kW SiC inverter was able to use approximately the same volume inductor as was required by the 10kW Si inverter.

In addition, many solar power inverter applications specify aluminum electrolytic capacitor banks. Due to their lower cost, these devices are much more likely to be primary failure points than their polypropylene film counterparts, which are typically more expensive. However, the higher frequency operation enabled by the SiC switching components reduces the number of film capacitors required while maintaining the same DC link voltage ripple, effectively enhancing overall system reliability.

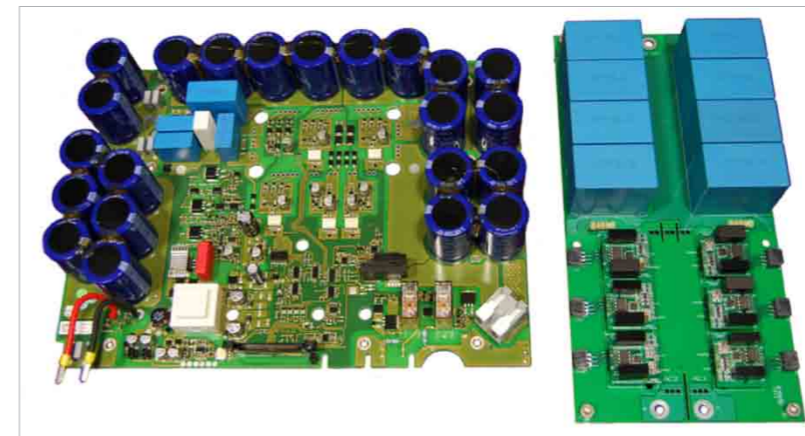

Figure 3: Comparison between Si 10kW inverter electrolytic capacitor bank (left) and the SiC 40kW inverter polypropylene capacitor bank (right)

As shown in Figure 3, the 40kW SiC inverter board realized significant PCB space savings when compared to the 10kW Si inverter layout. The bank of 22 aluminum electrolytic capacitors required for the 10kW output of the Si inverter are pictured on the left and the eight polypropylene film capacitors required for the 40kW output power of the SiC inverter are pictured on the right. Converting to SiC switching devices at the higher frequency greatly reduced the volume of capacitors per kW of delivered power. Even factoring in the higher unit cost of the film capacitors (8 polypropylene caps for ~\$118 at a 500-piece cost vs. 22 aluminum electrolytic caps at ~\$123 at a 500-piece cost), the component cost averages out in the much more efficient SiC-enabled inverter.

Thermal management requirements

Even though the power output of the inverter was boosted from 10kW to 40kW by implementing

the SiC power devices, the superior thermal characteristics of SiC allowed for the continued employment of the original heatsink, successfully avoiding adding additional volume or weight to the system despite a 4X increase in power output.

Moreover, in high-level simulations used to determine the link ripple voltage and output harmonic distortions of each baseline unit for comparison purposes, the SiC MOSFET module exhibited extremely low conduction losses, enabling the SiC system to double the delivered current while maintaining the same die size as the super-junction Si MOSFETs used in the 10kW inverter. Consequently, the SiC system was able to deliver four times the output power within the same footprint as the 10kW system.

SiC delivers 4X the output power
The example above clearly demonstrates that replacing

inefficient Si switching devices with SiC MOSFETs and diodes has the potential to quadruple the power density of an existing 10kW PV inverter system while also simplifying the topology, effectively delivering robust and reliable three-phase 480VAC output power in the exact same enclosure.

Higher output power, higher operating efficiencies, improved thermal characteristics, and higher operating frequencies can all be realized by using an all-SiC module design for solar inverters. Further, these inherent advantages enable designs with fewer and more reliable capacitive and inductive components, ultimately contributing to a lighter weight, more compact, and lower cost system capable of delivering more output power per dollar.

The aforementioned simulation and evaluation validates the considerable benefits of replacing the Si switching devices in existing solar inverter systems with all-SiC modules. However, it is reasonable to assume that a new design for next-generation solar power inverters optimized for SiC devices from the earliest stages of the design cycle could help achieve even higher efficiencies, cost savings, and power densities through optimized circuit design and magnetic/filter element selection.

www.cree.com

Italian project delivers zero-emission power from biomass

Four 1 MWe power stations, for a total of 4 MWe create the largest biomass power station in Italy

By: Ing. Alessio Vaccari, CPL Concordia,

CPL has recently inaugurated the largest agricultural biomass biogas power plant in Italy. Nine hectares of ground area, Four 1 MWe power stations, for a total of 4 MWe generated electricity for 10,000 households a year at zero emissions.

The largest agricultural biomass for biogas power production plant in Italy, engineered with the CPL Concordia know-how, was inaugurated last October at Bondeno (FE) by Paolo De Castro, the president of the European Parliament Agriculture and Rural Development Commission in Italy. This new power plant is built on a surface area covering nine hectares has four 1 MWe power stations, totaling an overall 4 MWe installed power to generate electricity supplies for almost 10,000 households each year. CPL Concordia, who engineered this project, are a multi-utility cooperative group that go back as far as the 1890s when they went into operation and now have 1500 employees and 80 other establishments.

A considerable amount has been

invested (20 million euro) to provide clean energy and reinforce the economical and social value attached to this operation while boosting the economical situation for local agriculture as well. Every year about 72,000 tons of raw material is collected and utilized in the power plants from surrounding farms up to 20 km away covering 1,500 hectares of cultivated farmland (Figure 1).

Objectives

This initiative has given life to the biggest national biomass biogas power plant: four electric power stations fed on biogas deriving from anaerobic digestion of agricultural biomass origin (fuel plants such as maize, sorghum, wheat).

The main objectives were to protect the environment and



Figure 1: 72,000 tons of raw material is collected and utilized in the power plants from surrounding farms up to 20 km away

stimulate agricultural production and to achieve this they first had to guarantee zero CO₂ emissions into the atmosphere. This was achieved by developing a mechanism in which the four power stations work in harmony with the plant growth cycles based on the principle that carbon dioxide emitted by combustion engines is equivalent to that absorbed by cereal plants during their plant cycle whereby a zero balance effect is created between the two entities of CO₂ emissions into the atmosphere. The second objective was to stimulate and guarantee agricultural production and this was done by convincing the local agriculture sector to cultivate the necessary raw material

with a 15-year return guarantee on merchandize at a fixed rate in cereal market stock exchange in Bologna.

How Biogas is produced

The anaerobic digestion consists of a biological fermentation process involving microorganisms (methanogenic bacteria) that, when deprived of oxygen, transform the carbohydrates, proteins and lipids (in the biomass fed into the power plant) into methane and carbon dioxide. The resulted biogas is 55% part methane and can sufficiently feed combined heating and electric production systems with internal combustion engines housed within the Bondeno power stations.

At this point it would be useful to emphasize that biogas energy use has a neutral CO₂ effect on the atmosphere because the same amount of CO₂ emitted by the biogas is equal to the same amount absorbed by plants (or consumed by animals indirectly when feeding on plant vegetation) therefore becomes part of the plant carbon cycle without worsening the greenhouse effect unlike fossil fuel combustion.

Another great ecological advantage of using biogas is that it prevents the spread of methane into the troposphere which is produced naturally during the decomposition of animal carcasses and plants: methane is in fact one of the most damaging greenhouse gases that produces a great amount of CO₂

that degrades the water content in the atmosphere being unfavorable for combustion.

The cost effective cogeneration systems have been purposely implemented to immediate this problem which work in such a way that heat is dispersed while the motors are running as well as improving system performances by more than 90%.

Biogas was previously purified in a cyro-treatment skid, while the produced electric energy is increased to a medium voltage rate and injected into the ENEL grid: both systems are designed by CPL.

Production Plants

The plant systems are composed of 4 SINCR0 1000 cogeneration 999 kWe modules programmed to work at least 8,500 hours a year: estimated Energy generated is equal to more than 8 million kWh for each motor, for a total of 32 million kWh.

The plant system uses Jenbacher JGS 320 GS- BL motors version C25 that offer extremely high performances, low emissions and exceptional reliability. The motor components have a life span of 60,000 hours of working use before routine servicing is performed.

Automation and Supervision

Particularly important is the plant's automation system essential for monitoring, efficient management and maintenance, as

well as analyzing historical system performance data. Each motor is equipped with a local control panel to monitor and control the running of motors using a PLC. CPL Concordia has applied each motor with a local supervision workstation which responds to the main centralized supervisory system housed in the onsite technical building which serves as the control centre for running the entire plant complex.

The CPL Cogeneration software department carried out a and the motor working parameters (alternator and cylinder temperatures, water and oil temperatures and pressures). Thanks to the Movicon Data Analysis tools, the recorded measures can be instantly extracted from the DB archives and effectively represented by applying filters, zooms and using curve overlapping tools along with a variety of other analysis functions.

Purposely designed reports have been provided within the Movicon Report Designer to represent data summaries by exploiting a great selection of charts and tables that can then be previewed and printed as pleased. Another particularly useful tool is the Movicon Web Browser that can be used in screen pages to connect and display dynamic HTML pages provided by the motor builders to display different parameters showing essential functional motor details for maintenance staff to analyze (Figure 2).

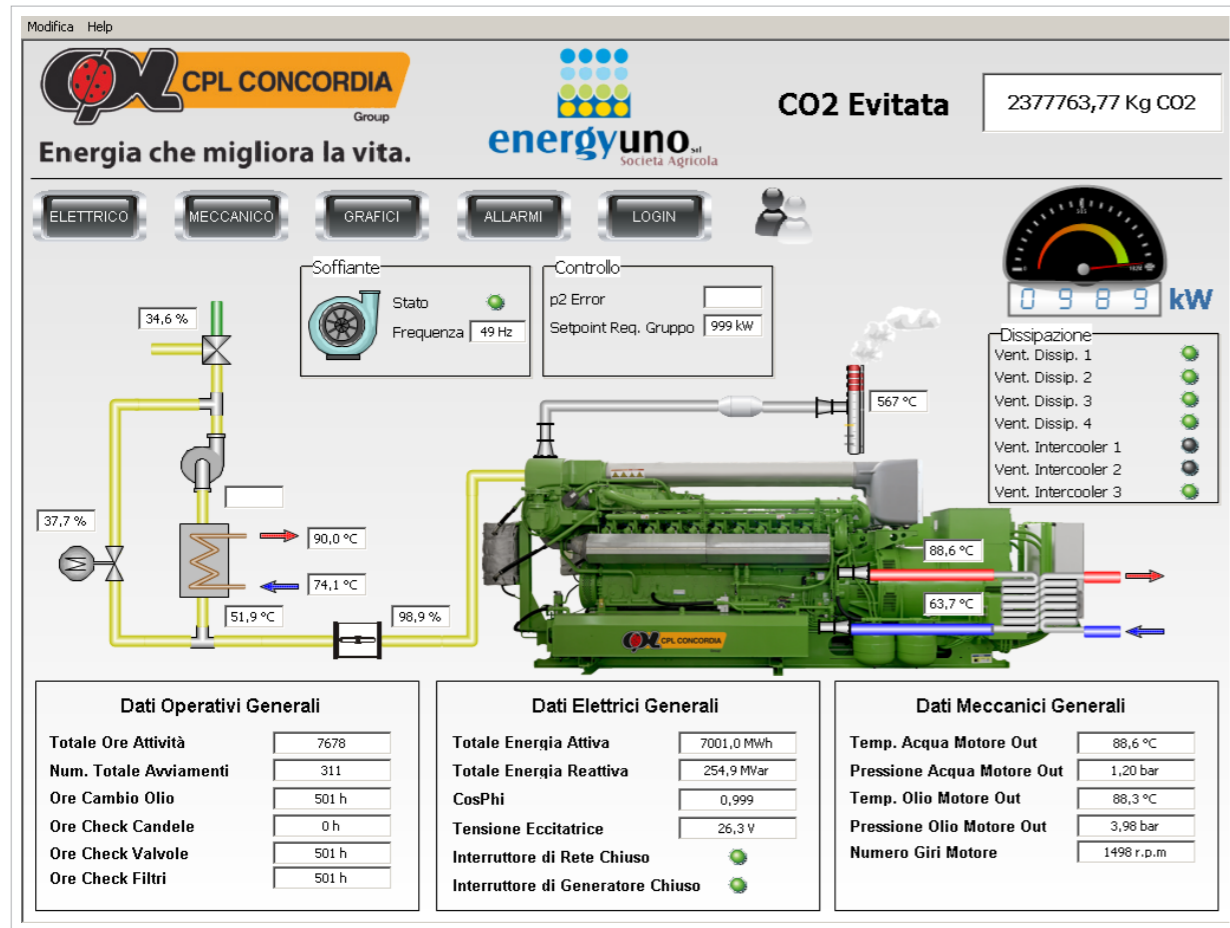

Figure 2: The plant supervision system is based on the Movicon 11 Scada/HMI platform for management and complete monitoring and control locally or via web

Movicon 11 Scada/HMI technology judged as being ideal for achieving the company's set objectives. The four local workstations with touch screen PCs communicate with the motors' PLCs to collect all operating statuses, alarms and alerts, together with all electric power, heating and process measures including data on the amount of gas produced by the anaerobic digesters. All the data is stored in a SQL Server database locally for analyzing electricity yield performance trends (power, voltage, current) To compliment efficient manag-

ment and maintenance, the in-built Movicon data analysis tools are extremely efficient in visualizing historical DB data according to client needs (Figure 3). System access is protected and regulated by a Login procedure based on pre-assigned security level and password. CPL Concordia has been entrusted with the maintenance of the whole system, so a lot of care has been dedicated by to establish a reliable on-call staff service to all maintenance workers according to work rotas. In addition to the statistical information, there is also an alarm manage-

ment, which has been designed for easy use and consultation with options to send notifications automatically via SMS using GSM modems enabled for each motor together with the Movicon Alarm Dispatcher. The Main Movicon Supervisor, housed in the technical control center, simply offers centralization of data deriving from each local workstation. Control center engineers can view all information on individual motor separately or altogether in one display with overall parameter aggregations.

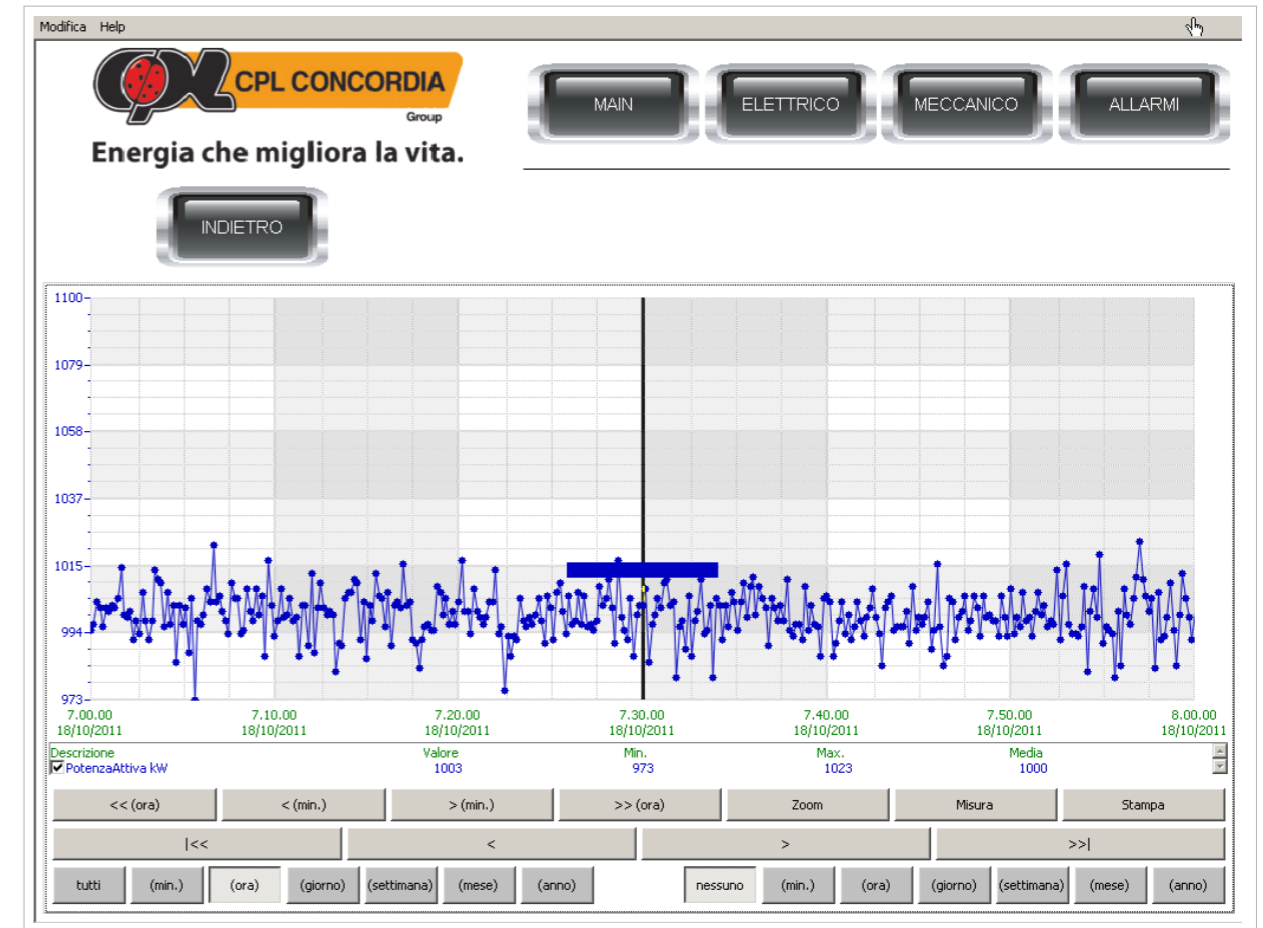

Figure 3: The Movicon data analysis tools are extremely efficient in visualizing historical DB data according to client needs.

Data is also stored in the control center on a relational DB based

on SQL Server in the main supervisory workstation. As the power

via internet possible by using the built-in Movicon Web Client.

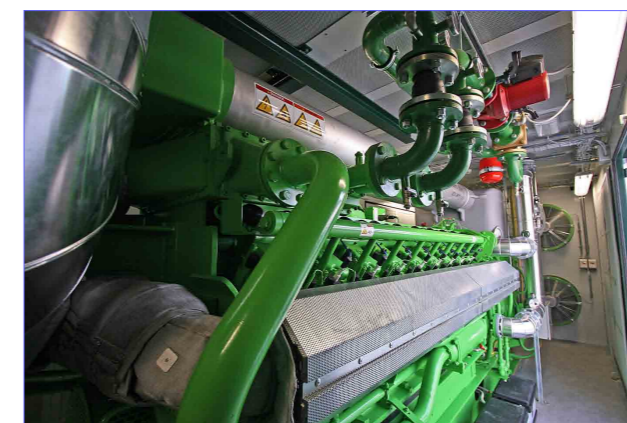

Figure 4: One of the 4 Jenbacher motors, situated in a container purposely designed to house all the process components needed for efficient system management

plant site covers quite a large area of ground (1.2 square Kms) each motor is connected to a public ADSL network using a Static IP address (Figure 4). This allows access to the supervision system

Web access to the system not only consents CPL Concordia, but staff or clients as well, wherever and whenever, to connect to the power plant system to check data and working statuses. In addition to all this, the CPL Concordia technicians have been exclusive permission to remote access the PC for maintenance purposes and interventions by using the Team Viewer tool.

www.cplconcordiausa.com

Nanopower energy harvesting dramatically extends battery life

Energy harvesting can drive the emerging market in compact, predominantly wireless applications

By: Jeff Gruetter, Linear Technology

Historically, remote wireless sensors have depended on batteries to provide power to measure data and transmit it wirelessly. This has worked reliably, but the usable life of these sensor networks is solely dependent that of the battery. In some applications, the wireless sensor nodes are accessible so the batteries can be changed relatively easily albeit at some cost, nevertheless these batteries are designed to last 5 to 10 years and are an expensive component in each sensor node. In other applications, changing the batteries is difficult, labor intensive and expensive. For example, consider changing the batteries of a wireless sensor in a nuclear power plant, a refinery or even underground. The costs associated can be substantial. Of course, bigger batteries may provide longer life, but the physical size and cost of larger batteries is not without cost. So the question becomes, "How does one make these batteries last longer?" One potential answer lies in finding another harvestable energy source to

operate the sensor node when it's available, running the node from the primary battery when it's not.

These applications have re-introduced the concept of energy harvesting from a very different perspective, creating an emerging market for compact, predominantly wireless applications at the very low end of the power spectrum. These applications require output power that ranges from a few nanowatts to tens of milliwatts. Although, non-traditional power sources such as solar cells (photovoltaic cells) and piezoelectric transducers are known sources of electrical power, harnessing power from these non-traditional sources has been challenging. Each of these sources requires some type of power conversion circuit that can efficiently collect, manage and convert this alternative power source into a more usable form of electrical energy to power sensors, microcontrollers and wireless transceivers. Whether the source voltage is higher than needed and must be down-converted to be useful or even rectified and

then down-converted in some cases, specific energy harvesting circuits are necessary. Historically, these circuits have needed very complex discrete circuits with upwards of 30 components and yet still struggle to provide high enough efficiency to be of practical use. It is only recently that specialized energy harvesting power ICs have been introduced, offering compact, simple and very efficient power conversion and management solutions in conjunction with the appropriate transducers.

These ultralow power applications include a wide array of wireless systems, including transportation, infrastructure, industrial sensing, building automation and asset tracking. These systems generally spend the majority of their operational lives in standby mode (asleep) requiring only a handful of μW . Then they wake-up, a sensor measures parameter(s) such as pressure, temperature or mechanical deflection and this data is then transmitted wirelessly to a remote system manager. The entire measurement, processing and transmission time is usually

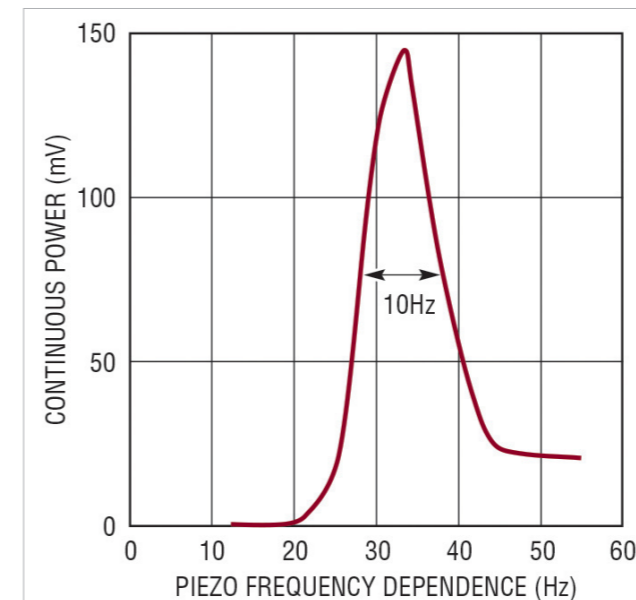

Figure 1: Power Delivered vs Piezo Frequency

only a few milliseconds, but requires tens of mW of power during this brief period. Since the duty cycles of these applications are generally low, the average power that must be harvested can also be relatively low. Although the power source could simply be a battery it will eventually need to be replaced. But if an energy harvesting design can use ambient energy most of the time and a battery is used when that energy source is unavailable, the battery life can be dramatically extended. A wireless network utilizing an energy harvesting technique can link any number of sensors together, for example, in a building to reduce heating, ventilation & air conditioning (HVAC) and lighting costs by turning off power to non-essential areas when the building has no occupants.

Energy Harvesting Case Study

the system. Each wireless sensor node (WSN) can have temperature, pressure and flow sensors built into them. Measurements must be taken and reported every five seconds. As a HVAC system is quite long and is usually buried deep in the infrastructure of the building, running power and information lines is very expensive and subject to constant maintenance, potentially requiring expensive repairs. Replacing batteries periodically incurs significant expense due to the labor-intensive exercise of getting to each of them.

One of the most popular and readily available ambient energy sources is vibration. A small piezoelectric transducer can easily convert vibration energy found on the HVAC compressor to low current AC electrical signal (Figure 1). This harvesting

Consider if you will an energy harvesting-based HVAC monitoring system such as forced air conduits in an industrial complex, which need to constantly monitor the airflow rate, temperature and pressure of

power source would need to be rectified and stepped-down to provide a usable low voltage to power a WSN. A battery could be used as a backup power source if the energy source is temporarily unavailable. However since the battery power is used only part time—the overall battery life is extended dramatically. Therefore, an energy harvesting IC that offers very high efficiency, ultralow quiescent current, and a seamless transition from the energy-harvesting source to the battery would be an ideal solution.

Battery Life Extender IC

The recently introduced LTC3330 is a complete regulating energy harvesting solution that delivers up to 50mA of continuous output current to extend battery life when harvestable energy is available. It requires no supply current from the battery when providing regulated power to the load from a harvested energy source and only 750nA operating when powered from the battery under no-load conditions. The LTC330 integrates a high voltage energy harvesting power supply, plus a synchronous buck-boost DC/DC converter that is powered by a primary cell battery to create a single non-interruptible output for energy harvesting applications such as those commonly found in WSNs. The energy harvesting power supply, consisting of a full-wave bridge rectifier accommodating AC or DC inputs and a high efficiency buck

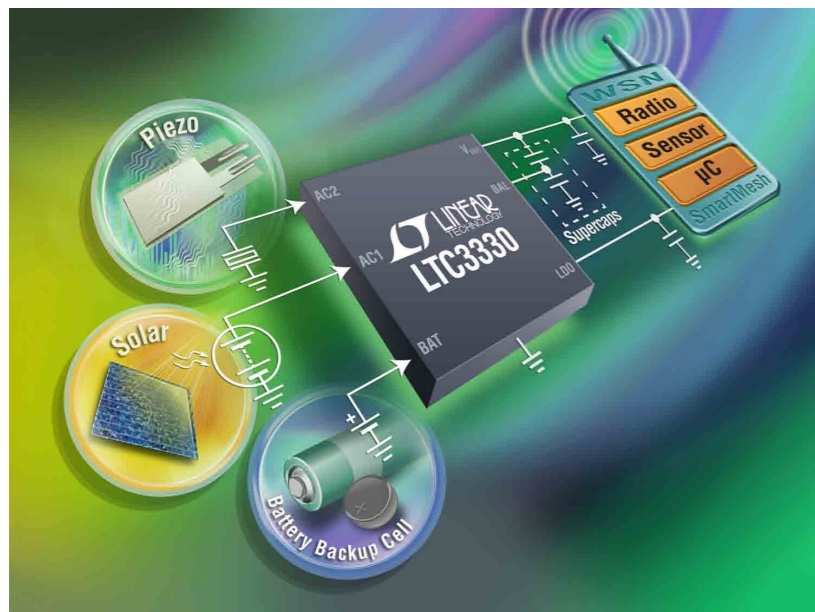

The LTC3330 automatically transitions to the battery when the harvesting source is not available (Figure 2).

The LTC3330's energy harvesting inputs operate from a voltage range of 3V to 19V, AC or DC, making it ideal for a wide array of piezoelectric, solar or magnetic energy sources. Its input undervoltage lockout threshold settings are programmable between 3V and 18V, enabling the application to operate the energy harvesting source at its peak power transfer point. Other features include programmable

Figure 2: The LTC3330 is a complete regulating energy harvesting solution

converter, harvests energy from piezoelectric (AC), solar (DC) or magnetic (AC) sources. The primary cell input powers a buck-boost converter that operates from 1.8V to 5.5V at its input when harvested energy is not available to regulate the output whether the input is above, below or equal to the output.

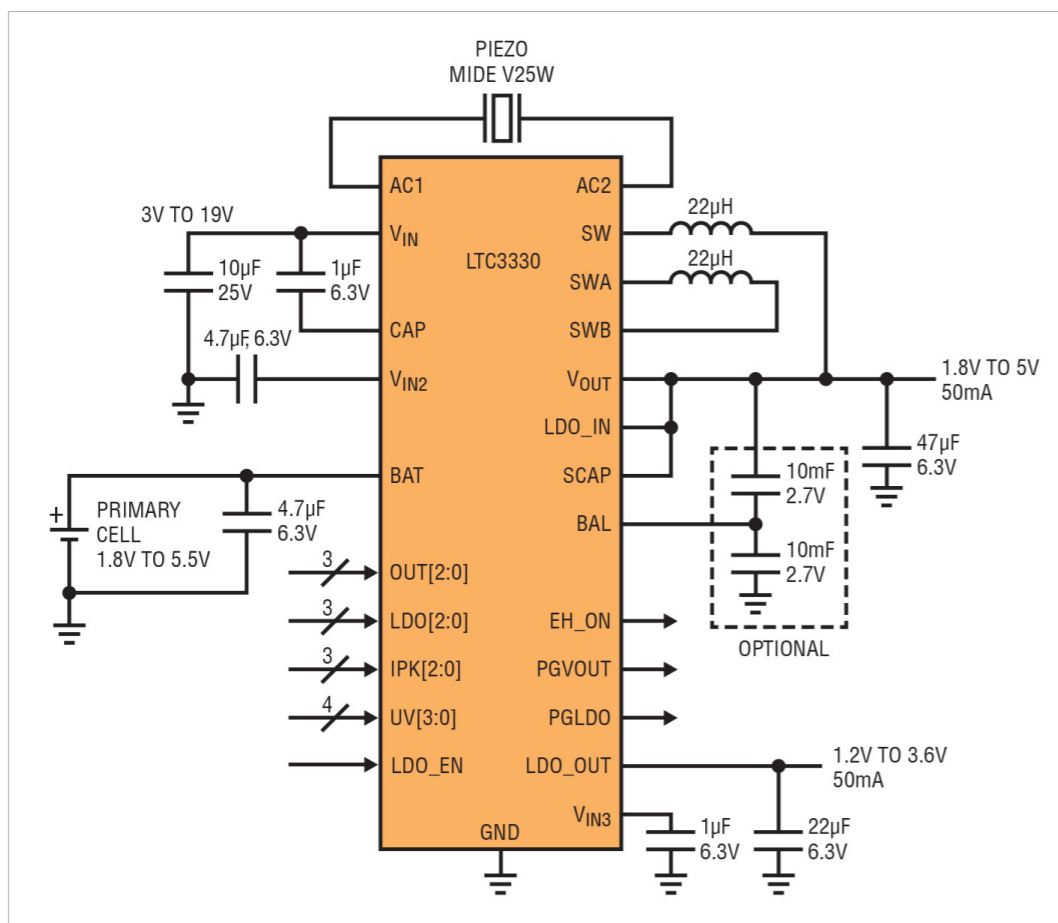

Figure 3: LTC3330 Piezo Electric EH /Primary Battery Schematic

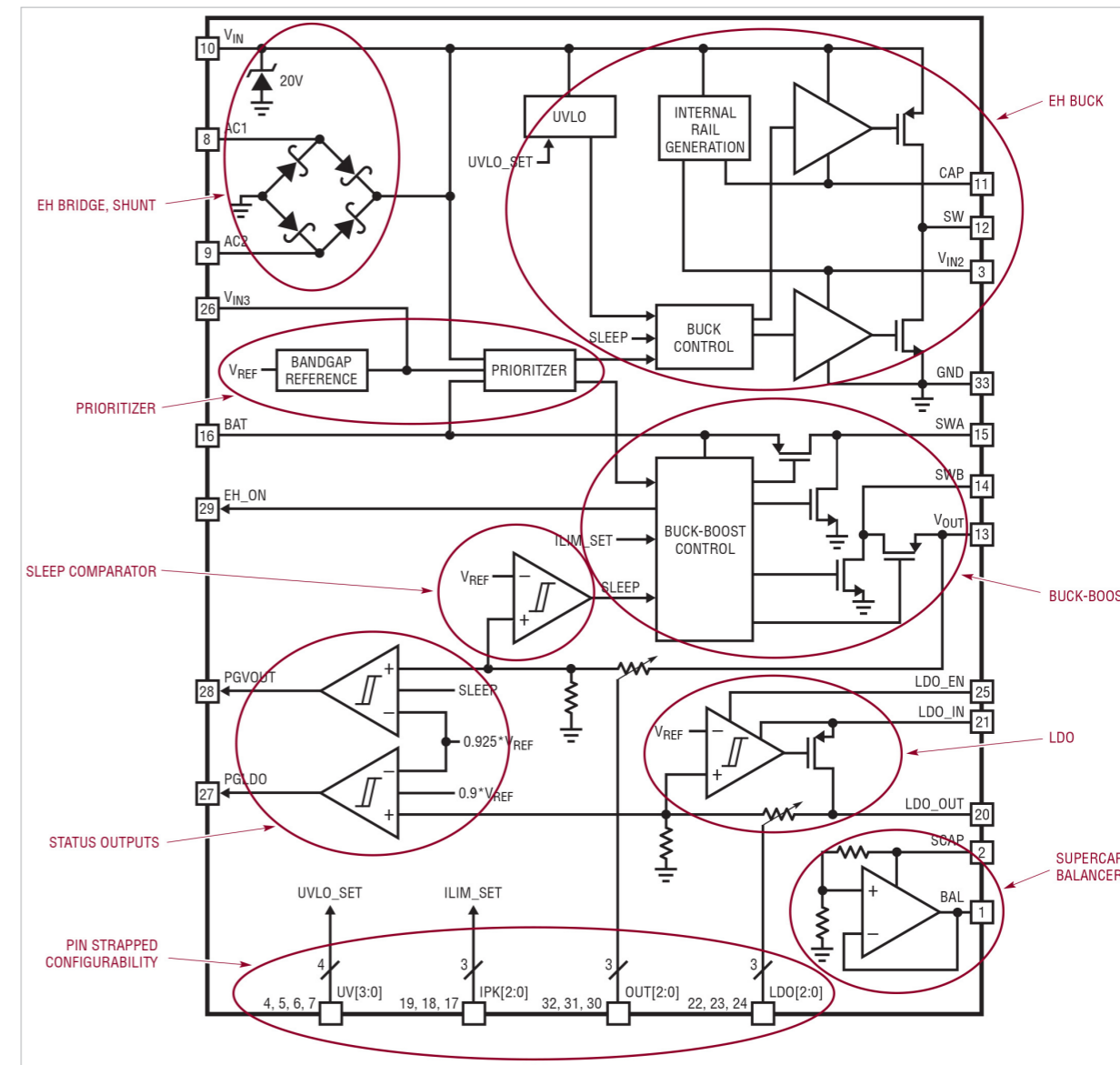

Figure 4: LTC3330 Block Diagram

DC/DC and LDO output voltages, buck-boost peak current limits, an integrated supercapacitor charger/balancer and an input protective shunt (up to 25mA at $V_{IN} > 20V$).

The circuit in Figure 3 shows the LTC3330 using an AC input from a piezoelectric transducer. Generally, applications will use

either a DC input on AC1, and possibly a second on AC2, or a single AC input connected across AC1 and AC2. If the energy-harvesting source is AC, such as from a piezo transducer, the LTC3330 has an integrated full bridge rectifier to deliver a DC voltage to the input capacitor whereas DC sources are stored directly on the input

capacitor. Once the voltage on the input capacitor exceeds the ULVO, the LTC3330's input prioritizer turns the battery off and regulates the output from the harvested source. V_{OUT} is pin programmable from 1.8V to 5V, which typically powers the RF transceiver. Additionally, an LDO output between 1.2V to 3.3V offers a low noise output,

typically used to provide core power to microprocessors. Combined, these two outputs can deliver up to 125mA of output current when using an energy harvesting source and 50mA when the battery is engaged. When there is excess output power in energy harvesting mode, it can be stored in the supercap(s) for future use, further conserving battery life. An integrated supercap balancer can be used to further optimize energy storage. It is important to note that when the energy-harvesting source is utilized, the battery has a zero quiescent current, so all of battery energy is saved for future use.

Figure 4 shows a more detailed view of the LTC3330's integrated functionality. The integrated full-bridge rectifier accommodates AC inputs such as piezoelectric or magnetic transducers to rectify their AC signals into DC signal. Obviously DC inputs such as solar cells do not require this rectification. If multiple transducer inputs are used, the LTC3330 uses the one with the highest available voltage (power). The input current is collected on the input capacitor and when it exceeds the programmable ULVO, the prioritizer turns the battery off and the synchronous step down converter delivers the required power to the output, where it is used for the load via the VOUT pin or the low noise LDO output; any excess power is

stored on the output capacitor and/or the supercaps. In this state there is zero quiescent current drawn from the battery. An input protective shunt offers an additional layer of safety for voltages in excess of 20V. If the energy harvesting input source is available, the prioritizer automatically switches over to the synchronous buck-boost converter to deliver the required output.

Both VOUT and VLDO stay in regulation throughout this transition, providing the required power to the sensor, wireless transmitter and microprocessor. The 1.8V to 5.5V input capability of the buck-boost converter accommodates a wide range of Li-Ion batteries. It delivers a constant voltage regardless of whether the battery voltage is above, equal to or lower than VOUT with efficiencies in excess of 90%. The buck-boost architecture offers over 30% more battery run time when compared to a conventional buck design. When operating from the battery, the total output current is dependent on the VIN/VOUT ratio and at the end of a Li-Ion batteries' life, which will be approximately 50mA. VOUT is the input to the low noise LDO output, which is pin programmable from 1.2V up to 50mV below VOUT, making it ideal for powering a wide variety of microprocessor/controller cores. An optional supercap balancer ensures the longest

life of this storage energy. Both VOUT and VLDO have power good status outputs to ease overall system operation.

So How Long Is Battery Life Extended?

Exactly how long battery life can be extended depends on the nature/availability of the ambient energy source and the overall power requirement of the WSN. In the aforementioned HVAC example, if the compressor is on all of the time, the entire system is run by the piezo EH source and the battery becomes a mere backup supply for when there is a power outage or the compressor is being serviced, thereby extending the battery life indefinitely.

As to how long battery life will be extended, the answer is, "It depends." Nevertheless, it lies somewhere between 2x and forever and is highly dependent on the design of the systems and input/output power duty cycles. Clearly, it is only possible if an EH IC is used to accommodate both an EH source complimented by a primary battery. Thus, this enables designers to use a smaller, less expensive battery in most cases.

www.linear.com

Supercapacitors enable energy harvesting in space-constrained apps

Supercapacitors avoid the need to size the entire system's power supply for the load's peak power

By: Pierre Mars, CAP-XX

Many applications require autonomous power. Examples include wireless sensors, displays such as electronic shelf labeling, and location tracking. In particular, wireless sensors are becoming ubiquitous. They can sense and report temperature for air conditioning or heating, they can save power by controlling light levels in a room depending on the ambient light measured, they can turn lights off if no motion is detected in a room, and they can be used for industrial control and condition monitoring of machines or structures, for security monitoring, or for location tracking. Using energy harvesting sources, which can obtain abundant energy from the environment, avoids the time-consuming and environmentally sensitive task of replacing and disposing of batteries.

Small energy harvesting sources such as solar cells, and vibration transducers such as microgenerators or piezo-electric units provide very low power, making it difficult

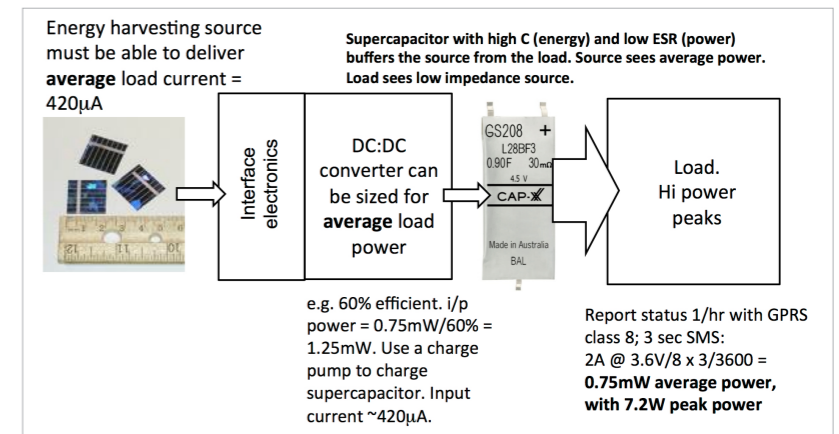

Figure 1: A supercapacitor's high energy storage and high power delivery make it ideal to buffer a high-power load

to drive tasks that require high power peaks, such as collecting, transmitting, or displaying data, from a low-power source. Prior to low-impedance supercapacitors, designers needed to size the entire power supply system for the load's peak power, as adding energy storage using other technologies would be space-prohibitive at the very least.

Supercapacitor advantages
For example, assume a remote location is reporting its status once an hour using an SMS that takes three seconds to transmit on

a GPRS cellular network. The peak output power is ~7W. The average power during the transmission = 7/8W for three seconds or ~2.6J. If a capacitor is at the input of a buck-boost to allow a wider voltage window, with a maximum voltage of 5V and minimum voltage of 2.5V, then input peak power will be ~7W/85% efficiency ~8.3W, and energy drawn will be ~3J.

To average the load with a capacitor you would require 0.4F with ESR < 50mOhms, or a supercapacitor. The only solution without a supercapacitor is to trickle-charge

a battery that can deliver 8W peak power, possibly with the support of a tantalum or electrolytic capacitor for the 0.577ms transmission peaks.

The supercapacitor's high energy storage and high power delivery make it ideal to buffer a high-power load from a low-power energy-harvesting source, as shown in **Figure 1**. The source sees the average load, which with appropriate interface electronics, will be a low-power constant load set at the maximum power point. The load sees a low-impedance source that can deliver the power needed for the duration of the high-power event. In this example, the average load power is only 0.75mW. A low-power energy harvester only needs to supply a little more than this power level (to overcome losses) to charge the supercapacitor to provide the GPRS module with the power required for transmission.

The supercapacitor is placed after the DC/DC converter, so designers can size the interface electronics and DC/DC converter for the average power of 1.25mW, rather than the peak power of 7W. It's important to note that a discharged supercapacitor will look like a short circuit to the source, so the interface electronics must manage the inrush current when the source is first connected to a supercapacitor at 0V.

Choice of supercapacitor

Designers should choose the supercapacitor so that it still has

sufficient voltage drop to support the load at the end of a peak power burst. ESR as well as C should both be considered. For example, a 1-second GSM burst to send an SMS draws a peak current of 2A for 0.577ms with a duty cycle of 1/8 with an average current of 250mA. If the supercapacitor is initially charged to 3.7V, it can drop to 3.4V and still support the GSM module.

Consider a CAP-XX GS230F supercapacitor (1.2F and 28mOhm ESR) after the 1s burst., The capacitance discharge = $1s \times 0.25A / 1.2F = 208mV$. Then the voltage drop due to ESR must be added = $2A \text{ peak current} \times 28mOhms = 56mV$. Therefore the total voltage drop during the SMS burst = $264mV$, so the minimum voltage at the end of the burst = $3.7V - 264mV = 3.46V > 3.4V$.

This calculation shows that the GS230 is suitable, but a 1.2F supercapacitor with 100mOhm ESR which would have a minimum voltage = 3.39V would be below the minimum 3.4V needed to support the GSM module. This illustrates the importance of ESR. Many engineers size the supercapacitor using an energy balance where $\frac{1}{2}C(V_{INIT2} - V_{FINAL2}) = Power.t$, but this approach implicitly assumes ESR = 0, so undersizes the supercapacitor.

Supercapacitor form factor, which can be cylindrical, prismatic, or "coin" shaped, is also a consideration. Designers needing to accommodate space-constrained



Figure 2: Designers needing to accommodate space-constrained designs might consider thin prismatic supercapacitors

designs might consider thin prismatic supercapacitors (**Figure 2**) as a power buffer to store the energy from the harvester to provide high power to the application.

The harvester/supercapacitor interface

There are four key principles that any circuit charging a supercapacitor from an energy harvester must adhere to:

- Start charging from 0V
- Provide over-voltage protection for the supercapacitor
- Prevent the supercapacitor from discharging back into the energy harvester when ambient energy levels drop

Using a small solar cell with a supercapacitor

A solar cell power output is typically quoted at 50,000 lux or 1KW/m2 = 100,000 lux. This does not relate to typical conditions of use, often with indoor lighting, typically from 300 to 500 lux. First you should characterize your cell with the light source(s) you intend to use, easily

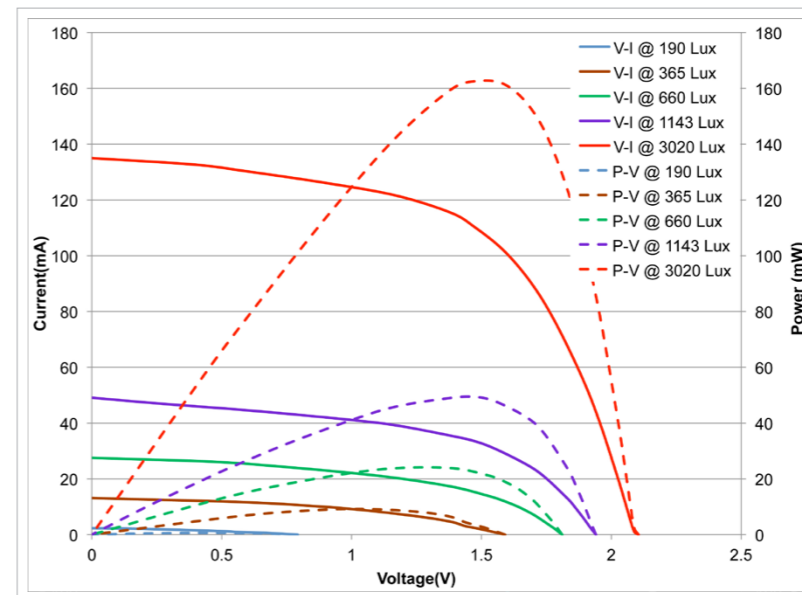

Figure 3: The V-I and P-I curves for the solar cell

shows the power profile of this application, supplied by the solar cell and circuit of **Figure 4**. The solar cell cannot support this application without the supercapacitor acting as a power buffer to supply the 150mW peaks. With the supercapacitor, the energy harvester can supply this application indefinitely in indoor light.

In our example, the LTC3105 boost converter supercap charging circuit power IC takes an input down to 0.25V, for low-light operation, behaves gracefully into a short circuit when the supercapacitor is fully discharged to 0V, and has an

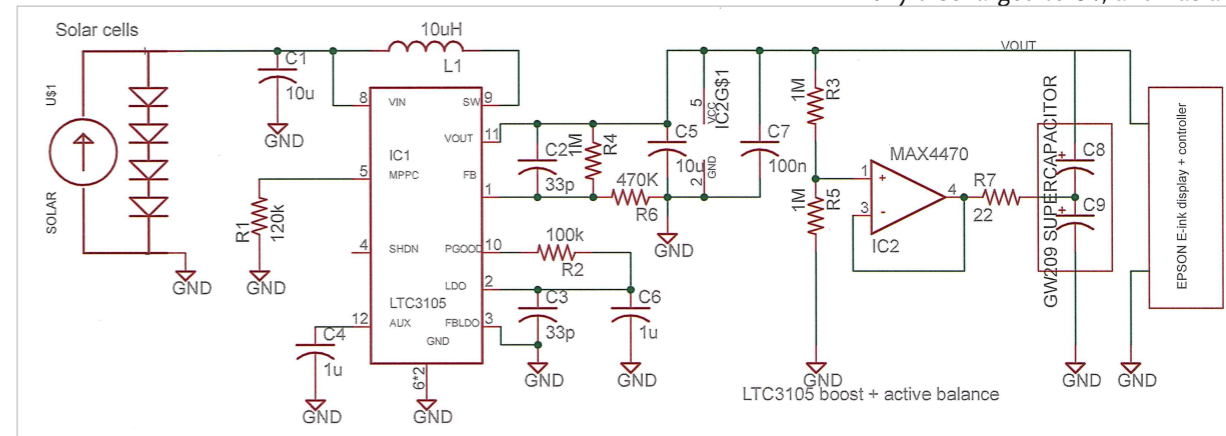

Figure 4: An e-ink display, updated 1/minute

done by placing a potentiometer across the cell and varying the resistance and measuring the voltage across the potentiometer and its resistance. From this you obtain V-I and P-I curves for your solar cell, as shown in **Figure 3**. They show that at 365 lux the maximum power the solar cell can deliver is ~8mW. For this light level, 8mW is the maximum average power possible for an application. Average power can be controlled by varying the reporting / updating rate of an

application, as per the example of **Figure 1**.

Several ICs have been released that meet the principles for a supercapacitor charging circuit outlined above, such as the LTC3105n from Linear Technology. **Figure 4** shows an e-ink display, updated 1/minute, with average power of 5.6mW from the solar cell characterised in **Figure 3**, and peak power of 153mW provided by CAP-XX's GW209 supercapacitor. **Figure 5**

efficiency of ~70% at 2mW. Maximum peak power tracking is set by R1, and the input current is limited to keep the solar cell voltage near its maximum power point (**Figure 3** shows this as ~1.2V at 350 Lux). It does not provide midpoint cell balancing for a dual cell supercapacitor, unlike some other supercapacitor chargers. In our circuit, low current active balance is provided by IC2, the MAX4470.

Using a vibration transducer with

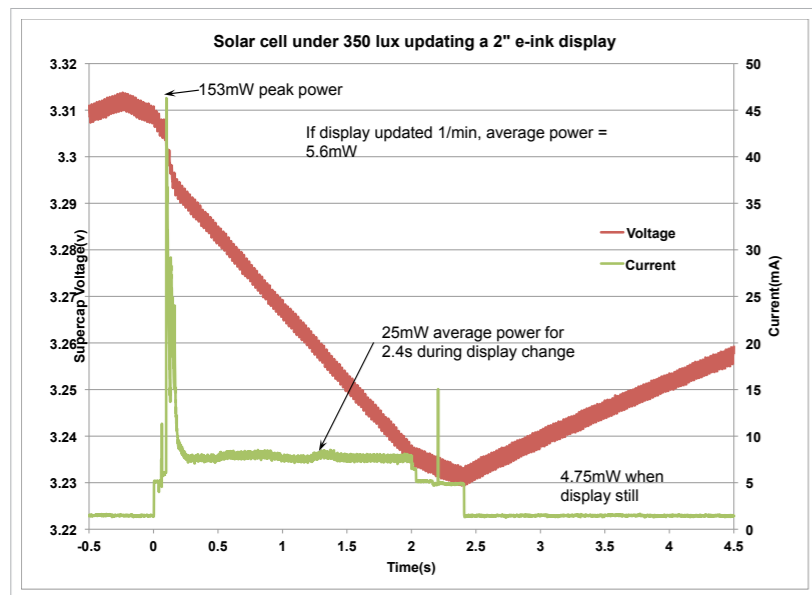

Figure 5: the power profile of the e-ink application

a supercapacitor

There are many instances where vibration is an abundant energy source such as monitoring of rotating machines and location tracking in rail or vehicles. You should characterize your vibration transducer in the same manner as described for the solar cell. We used a Perpetuum microgenerator, which provided a maximum power of 15mW at 7V when attached to our rotating machine. (We used this to power the same e-ink display application used in our solar cell example.) In this case we chose the LTC3330 supercapacitor charging circuit, shown in the circuit of Figure 6.

Conclusions

With our vibration source and energy harvester, this application will run indefinitely. Like the solar cell example, the vibration energy harvester cannot supply the peak power, and this circuit only works

piezo vibration energy harvester, and operates at ~90% @ 3mW with active balancing for a dual cell supercapacitor. It does not include peak power tracking, but since this is a buck converter, $V_{in} > V_{out} = 3.3V$. The characterization of our vibration transducer has shown that with our vibration source, power at $3.3V = 8mW$, which is > average power of our application.

We have given examples using two common energy sources, light and vibration, how an application can be powered indefinitely, eliminating the need for batteries. There

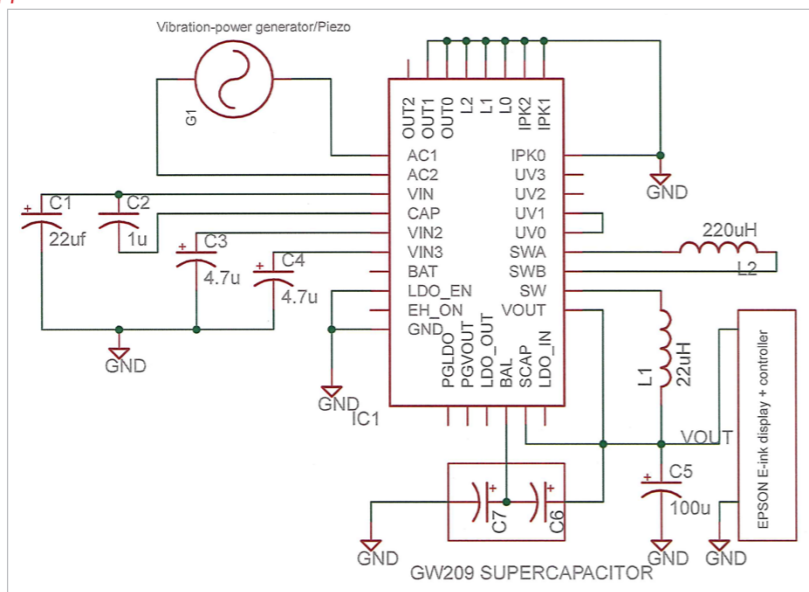

Figure 6: The LTC3330 supercapacitor charging circuit

with the supercapacitor providing the peak 150mW power for display updates. In this example, the LTC3330 behaves gracefully into a short circuit and provides charge current to the supercapacitor when it is fully discharged to 0V. It also includes a diode bridge for full wave rectification of the input from a micro-generator or

is abundant energy available from the environment, but at power levels too low to drive most applications. Using a supercapacitor as a power buffer, charged at low power from an energy harvester, and supplying intermittent peak power to the load makes these applications possible.

www.Cap-Xx.com

PCIM

EUROPE



International Exhibition and Conference for Power Electronics, Intelligent Motion, Renewable Energy and Energy Management Nuremberg, 20–22 May 2014

This is your powerful connection!

The marketplace for developers and innovators. Future starts here!



Nuclear power's problems

By: Alix Paultre, Editorial Director, PSD

Nuclear power has always been a controversial technology, and recent events have led many in the world to question whether or not we should continue to use the technology for power generation. Nuclear power is (no pun intended) a very powerful energy source that can serve us into the foreseeable future, but it also brings with it ramifications that also extend into the foreseeable future and beyond. Only by properly addressing the risks in a realistic manner can we ensure that nuclear power remains a servant of mankind, not a threat to it. The previous nuclear accidents at Three Mile Island and Chernobyl are relatively minor incidents compared to the ongoing horrific disaster that is Fukushima, which threatens to disrupt significant parts of Japan, and could potentially threaten its integrity and sovereignty if the disaster footprint extends.

This disaster has been complicated by the poor response, bad decisions, and incompetent handling of the situation in the escalation to crisis and the ongoing mitigation effort. Decisions made to save money are now jeopardizing the health and safety of millions of people and could cause the end of the Alaska salmon

fisheries, among other critical Pacific fisheries.

The chain of bad decisions began with the choice to build the facility closer to the shore at a location excavated to make it level (bringing it closer to groundwater) to save money, and extend to the almost comical (if weren't terrifyingly serious) mistakes in the cleanup effort from bad wastewater tank construction to workers accidentally shutting off major systems. This impression of indifference and incompetence damages the image of nuclear power as a viable energy source going forward.

Frankly, the world needs a corny-science-fiction-movie-level effort to mitigate and contain the disaster, as the currently situation is untenable and can very easily result in a greater problem. The current operation to remove 400 tons of highly irradiated spent fuel beneath the plant's damaged Reactor No. 4 could result in the material being spilled, creating

an even larger disaster. If the cleanup effort on the facility cannot secure the rods, the disaster exclusion zone may need to be extended to a couple of hundred kilometers, a distance that threatens Tokyo with evacuation.

Nuclear power can be a useful, safe source of energy. Done properly, fuel-rod management and radioactive material containment can be safe. However, if the nuclear industry does nothing to learn from the lessons of Fukushima not only would we be poorly served as an industry, but we will also create the potential for even greater disasters. The Indian Point nuclear plant 50 miles north of NYC has three times the fuel material at Fukushima, for example. Only by developing and building plants with secure and safe on-site semi-permanent storage and robust and redundant safety systems can we in good faith continue to develop and deploy nuclear power.

www.powersystemsdesign.com



Power supply trouble?



4-Day Lab Design Workshops: 7-10 January 2014, Atlanta, GA USA 3-6 February 2014, Cambridge UK

Need help with your current project? Want to become a more efficient designer? Our mission is to teach and clarify the power supply design process. Regardless of the power converter you are working on, this essential hands-on workshop will provide the needed skills in topologies, magnetics, and control to be a much more focused and efficient designer. Design and build two real-world converters at 25 W and 60 W in the afternoon laboratory, and measure ringing waveforms and

efficiency. Intensive voltage-mode and current-mode models and design procedures are given and confirmed in the lab.

New: digital control introduction

As part of the control series, Dr. Ridley will give an introduction to digital control. He will discuss where to apply it, the advantages and disadvantages, and the impact on your project.

Visit our website to register. WWW.RIDLEYENGINEERING.COM



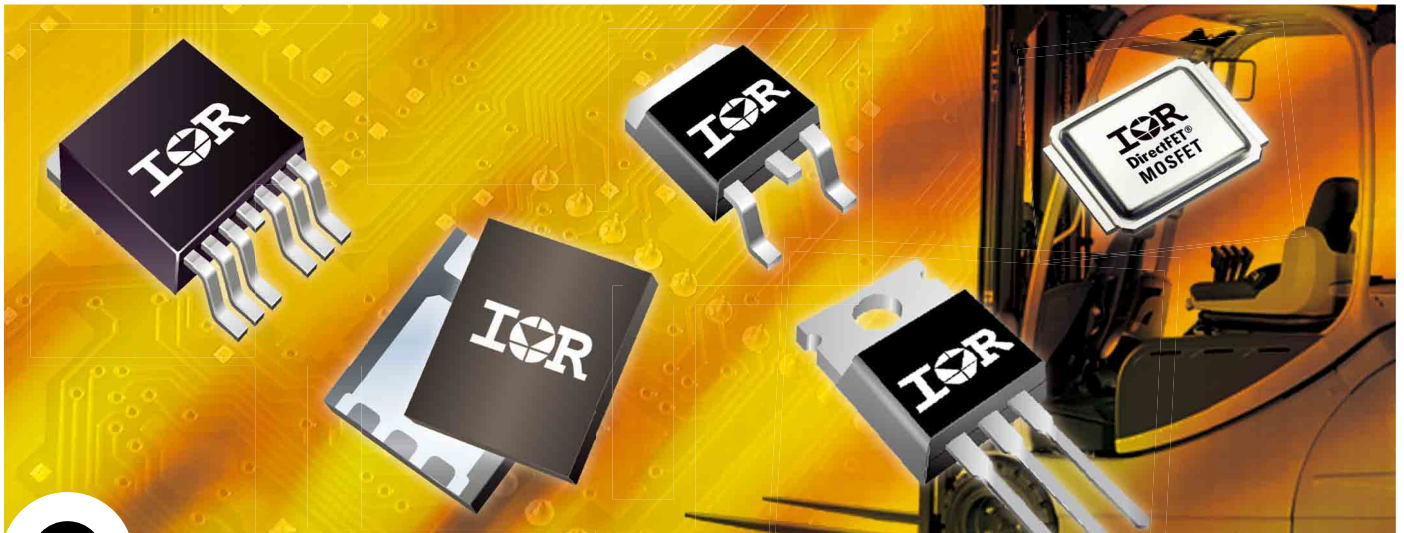

Rugged, Reliable MOSFETs for Industrial Applications

Part Number	V_{DS} (V)	$R_{DS(on)}$ Max. VGS=10V (mΩ)	I_D (A)	Q_G (nC)	Package
IRF7739L2	40	1	270	220	DirectFET-L8
IRFB7430	40	1.3	409	300	TO-220
IRFH7004	40	1.4	259	129	PQFN 5x6 mm
IRFS7440	40	2.5	208	90	D ² PAK
IRFS3006-7	60	2.1	240	200	D ² PAK-7
IRFS3006	60	2.5	195	200	D ² PAK
IRFH5006	60	4.1	100	67	PQFN 5x6 mm
IRF7749L2	60	1.3	108	220	DirectFET-L8
IRFB3077	75	3.3	210	160	TO-220
IRFH5007	75	5.9	100	65	PQFN 5x6 mm
IRF7759L2	75	2.2	83	220	DirectFET-L8
IRFP4468	100	2.6	195	360	TO-247
IRFH5010	100	9	100	65	PQFN 5x6 mm
IRF7769L2	100	3.5	124	200	DirectFET-L8
IRFS4010-7	150	4	190	150	D ² PAK
IRFS4010	150	4.7	180	143	D ² PAK
IRFH5015	150	31	56	33	PQFN 5x6 mm
IRF7779L2	150	11	67	97	DirectFET-L8
IRFP4668	200	9.7	130	161	TO-247
IRFH5020	200	59	41	36	PQFN 5x6 mm
IRFP4768	250	17.5	93	180	TO-247
IRFH5025	250	100	32	37	PQFN 5x6 mm
IRF7799L2	250	38	35	110	DirectFET-L8

Features

- Low on resistance per silicon area
- Optimized for both fast switching and low gate charge
- Excellent gate, avalanche and dynamic dv/dt ruggedness

The IR Advantage

- Best die to footprint ratio
- Large range of packages
- Available from 40 V to 250 V

Applications

- DC Motor Drives
- Uninterruptible Power Supplies (UPS)
- DC-DC Converters
- Power Tools
- Electric Bikes

**Your FIRST CHOICE
for Performance**

For more information call +49 (0) 6102 884 311

or visit us at www.irf.com

International
IOR Rectifier
THE POWER MANAGEMENT LEADER